

Simply
Good and Beautiful
MATH

4

COURSE BOOK

Table of Contents



About the Course.....	iv
Frequently Asked Questions.....	v
Unit 1.....	1
Lesson 1: Numbers in Nature.....	2
Lesson 2: Addition Review.....	6
Lesson 3: Subtraction Review.....	9
Lesson 4: Solving for Unknowns.....	12
Lesson 5: Multiplication Review.....	15
Lesson 6: Division Review.....	18
Lesson 7: Place Value.....	21
Lesson 8: Expanded Form.....	24
Lesson 9: Writing Numbers.....	28
Lesson 10: Geometry.....	31
Lesson 11: Rounding to the Millions.....	34
Lesson 12: Mental Math: Addition.....	37
Lesson 13: Rays and Angles.....	40
Lesson 14: Polygons.....	43
Lesson 15: Fractions.....	46
Lesson 16: Review Games.....	49
Lesson 17: Mental Math: Subtraction.....	52
Lesson 18: Elapsed Time.....	55
Lesson 19: Adding and Rounding to Any Place Value.....	58
Lesson 20: Subtracting Across Zeros.....	61
Lesson 21: Fractions and Mixed Numbers.....	64
Lesson 22: Comparing and Ordering Large Numbers.....	67
Lesson 23: Reading a Ruler and Inch Scale.....	70
Lesson 24: Estimating Answers: Addition/Subtraction.....	74
Lesson 25: Elapsed Time: Start and End Times.....	77
Lesson 26: Multiplication: Multi-Digit by One-Digit.....	80
Lesson 27: Adding Three or More Addends.....	83
Lesson 28: Fractions Equal to One-Half or One.....	86
Lessons 29–30: Unit Assessment.....	90

Unit 2.....	97
Lesson 31: Volume: US Customary System.....	98
Lesson 32: Multiplying by 100/1,000/10,000.....	101
Lesson 33: Volume: Metric System.....	104
Lesson 34: Similar and Congruent Figures.....	107
Lesson 35: Equivalent Fractions.....	111
Lesson 36: Perimeter and Area: Part 1.....	114
Lesson 37: Exponents and Perfect Squares.....	118
Lesson 38: Comparing Fractions.....	121
Lesson 39: Associative Property.....	124
Lesson 40: Order of Operations.....	128
Lesson 41: Long Division: Part 1.....	131
Lesson 42: Multiples and Factors.....	134
Lesson 43: Graphs.....	137
Lesson 44: Fact Family Logic.....	140
Lesson 45: Symmetry.....	144
Lesson 46: Fahrenheit and Celsius.....	147
Lesson 47: Long Division: Part 2.....	150
Lesson 48: Fractions of a Set: Part 1.....	153
Lesson 49: Collecting Data.....	156
Lesson 50: Graphing Data.....	159
Lesson 51: Long Division: Part 3.....	162
Lesson 52: Prime and Composite Numbers.....	165
Lesson 53: Improper Fractions.....	168
Lesson 54: Finding Missing Factors.....	171
Lesson 55: Types of Triangles.....	175
Lesson 56: Perimeter and Area: Part 2.....	178
Lesson 57: Two-Step Story Problems.....	181
Lesson 58: Long Division: Why It Works.....	184
Lessons 59–60: Unit Assessment.....	188

Unit 3	195
Lesson 61: Multiplication: Multiples of 10	196
Lesson 62: Quadrilaterals	199
Lesson 63: Long Division: Part 4	203
Lesson 64: Geometric Transformations.....	206
Lesson 65: Rotations	209
Lesson 66: Adding and Subtracting Fractions.....	213
Lesson 67: Reducing Fractions	216
Lesson 68: Perimeter and Area: Part 3.....	219
Lesson 69: Long Division: Part 5	222
Lesson 70: Geometric Solids	225
Lesson 71: Volume: Rectangular Prisms.....	228
Lesson 72: Converting Mixed Numbers to Improper Fractions.....	232
Lesson 73: Decimals	235
Lesson 74: Radius and Diameter	238
Lesson 75: Roman Numerals.....	242
Lesson 76: Decimals and Fractions.....	244
Lesson 77: Long Division: Zero in the Quotient.....	247
Lesson 78: Distributive Property	250
Lesson 79: Length: US Customary System	253
Lesson 80: Length: Metric System.....	256
Lesson 81: Division with Remainders.....	260
Lesson 82: Tessellations	263
Lesson 83: Mixed Numbers and Division.....	266
Lesson 84: Two-Digit Multiplication: Part 1.....	269
Lesson 85: Advanced Patterns.....	272
Lesson 86: Two-Digit Multiplication: Part 2.....	275
Lesson 87: Adding and Subtracting Decimals.....	278
Lesson 88: Naming Geometric Figures.....	282
Lessons 89–90: Unit Assessment	286

Unit 4	293
Lesson 91: Positive and Negative Numbers.....	294
Lesson 92: Rounding Decimals: Part 1.....	297
Lesson 93: Comparing and Ordering Decimals.....	300
Lesson 94: Comparing Positive and Negative Numbers	303
Lesson 95: Multiplication: Three-Digit by Two-Digit	306
Lesson 96: Adding and Subtracting Mixed Numbers.....	309
Lesson 97: Long Division: Dividing by 10.....	314
Lesson 98: Rounding Decimals: Part 2.....	318
Lesson 99: Fractions of a Set: Part 2.....	321
Lesson 100: Fractions, Mixed Numbers, and Decimals	324
Lesson 101: Long Division: Multiples of 10	327
Lesson 102: Weight: US Customary System	330
Lesson 103: Decimal Numbers: Multiplication and Division	333
Lesson 104: Weight: Metric System	336
Lesson 105: Game Lesson: Coordinate Planes	339
Lesson 106: Estimating Answers: Multiplication and Division.....	342
Lesson 107: Mental Math: Multiplication	346
Lesson 108: Long Division: Two-Digit Divisor Part 1.....	349
Lesson 109: Probability	352
Lesson 110: Multiplying Decimals by Whole Numbers	356
Lesson 111: Long Division: Two-Digit Divisor Part 2.....	359
Lesson 112: Mental Math: Short Division	362
Lesson 113: Dividing Decimals by Whole Numbers	365
Lesson 114: Average and Mean.....	368
Lesson 115: Median, Mode, and Range	371
Lesson 116: Percents.....	374
Lesson 117: Review Game: Units 1 and 2.....	378
Lesson 118: Review Game: Units 3 and 4.....	382
Lessons 119–120: Course Assessment	386

Reference Guide	394
Multiplication Mastery Chart	395



ABOUT THE COURSE

Supplies Needed

- 📖 *Simply Good and Beautiful Math 4 Course Book*
- 📖 *Simply Good and Beautiful Math 4 Answer Key*
- 📖 *Math 4 Mental Math Map Mysteries*
- 📖 *Simply Good and Beautiful Math Scratch Pad* or other scratch paper
- 📱 Device to access videos (highly recommended)
- ✎ Pencils
- 🖍 Crayons or colored pencils (keep on hand)
- 📏 12-inch ruler
- 🎲 Dice

Course Overview

Math 4 consists of 120 lessons divided into four units. Each unit ends with an assessment. The course is designed to be completed by the child independently, but parents/teachers can choose to be as involved in the lessons as they would like to be.

Lesson Overview

Most lessons are 3–4 pages and consist of four parts: video lesson, mini lesson, lesson practice, and review.

Video Lesson: Themed videos provide detailed teaching and interactive guided practice of the lesson topic. Scan the QR code or go to godandbeautiful.com/Math4 to access the videos.

Mini Lesson: A concise written lesson on the topic.

Lesson Practice: Practice that is dedicated to the lesson topic.

Review: Daily review of topics from previous lessons, including daily review of multiplication facts.

A Reference Guide is included at the end of the course book.

Getting Started

Simply open the course book. Students may choose to watch the video lesson or to read just the mini lesson. Please note that videos may contain material not included in the written mini lesson. After completing the video and/or mini lesson, the student should complete the lesson practice and review sections. Parents/teachers should grade their child's work daily and provide immediate help and feedback. Students who struggle with the lesson practice should be encouraged to review the mini lesson or the video for help.

Students should complete one section in their *Math 4 Mental Math Map Mysteries* book each time they complete a math lesson.

Lesson 28: FRACTIONS EQUAL TO ONE-HALF OR ONE

Video Lesson: Scan the QR code or watch the video lesson on godandbeautiful.com/Math4. The section below is used during the video.

Mini Lesson: When writing a fraction in standard form, we name the numerator (top number) first, write a hyphen, and then name the denominator (bottom number) as an ordinal number. Look at these examples of fractions and their word forms. Note that one-half is an exception to the rule.

Examples: $\frac{1}{2}$ one-half, $\frac{1}{4}$ one-fourth, $\frac{7}{8}$ seven-eighths, $\frac{1}{3}$ one-third, $\frac{3}{5}$ three-fifths, $\frac{1}{10}$ one-tenth, $\frac{2}{10}$ two-tenths, $\frac{5}{10}$ five-tenths, $\frac{10}{10}$ ten-tenths.

If the numerator of a fraction is half of the denominator, then the fraction is equal to $\frac{1}{2}$. In the fractions shown below, notice that the top number of each fraction is exactly half of the bottom number. Each fraction below is equal to $\frac{1}{2}$.

Fractions with an odd number in the denominator cannot be written as a fraction to equal one-half with a whole number in the numerator, because you get a mixed number when you divide an odd number in half. We don't normally write a mixed number as a numerator.

Quick Tip! Fractions can name whole numbers, too. All the parts together of each circle below make up a whole. Examples of fractions that name one whole are two halves, three thirds, four-fourths, and five-fifths. If the numerator and the denominator are the same, the fraction is equal to 1.

Lesson Practice:

- Fill in the missing information. The first has been done for you.
- Circle all the fractions that equal $\frac{1}{2}$ and put a box around all the fractions that equal 1.

ROBOT REVIEW

- How long are the robot's legs to the nearest inch?
- Which two polygons make up the robot's eyes?
- How many pentagons can you find on the robot?
- Find a polygon on the robot made up of four right angles and trace it in purple.
- Color five octagons green.
- Find and trace a pair of vertical parallel lines in red.
- Which four polygons make up the robot's feet?
- How tall is the robot to the nearest half inch?
- Find a polygon on the robot with six obtuse angles and color it brown.
- Color nine pentagons orange.
- How many triangles did you find on the robot?
- Find three right angles and draw a small square in the corner of each one.
- Trace a pair of horizontal parallel lines in blue.

Frequently Asked Questions

How many lessons should my student do each week?

- There are 120 lessons in the course. If your student completes four lessons per week, he or she will complete the course in a standard school year with typical breaks for vacation or sickness.

How long do lessons take?

- The average time to complete a lesson is 35–45 minutes. This includes time to watch the video, complete the practice and review sections, and practice multiplication facts.

What if my child is too slow/fast?

- If your child takes longer than average but is understanding and retaining information, don't worry. You may want to break up the lessons. Complete the video and lesson practice at one time and the review section at another time.
- To avoid holes in his or her math foundation, we suggest not skipping entire levels if your child works more quickly than average but is learning new concepts. Consider having your child do multiple lessons a day to complete the course faster.
- If your child takes less time than average and seems to already know all the information, consider giving the Unit Assessments to see if he or she can skip any units or move on to the next course. Remember, the first few lessons of the course are review from Math 3, and it's expected that most students will know the information already.

What if my child cannot remember concepts?

- In the back of the course book is a reference guide. This page may be useful for your student to refer to as he or she is completing difficult concepts that require memorizing information such as conversions, volume, perimeter, area, long division, etc.

Does my student have to watch the videos?

- The videos contain the bulk of the teaching and are highly recommended. However, if your student feels confident in the topic being taught, he or she can skip the video and read the mini lesson instead. A student who struggles with the lesson practice should be encouraged to go back and watch the video.
- Some families prefer to have the parent/teacher teach the child using the mini lesson rather than have the child watch the video lesson independently.

Is Math 4 completed independently by the child?

- Yes, Math 4 is designed for your student to mostly complete independently, though at times children may need parent/teacher assistance to understand a concept. Parents/teachers will need to grade their child's work and should do so on a daily basis when possible, providing immediate feedback.

Is Math 4 a spiral or mastery program?

- Math 4 is mainly a spiral course, constantly reviewing concepts your student has learned to ensure understanding and retention of information.

What if there isn't room to complete the work?

- Students should always keep scratch paper on hand while completing the lessons. The *Simply Good and Beautiful Math Scratch Pad* is available for purchase.



Do you include any specific doctrine?

- No, the goal of our curriculum is not to teach doctrines specific to any particular Christian denomination but to teach general principles such as honesty, hard work, and kindness. All Bible references in our curriculum use the King James Version.





UNIT 1 OVERVIEW

LESSONS 1-30

Extra Supplies Needed

-  ruler
-  colored pencils or crayons





















New Concepts Taught

-  commutative property of multiplication
-  compare numbers through hundred millions
-  estimations (sums and differences)
-  measurement to a quarter inch
-  order numbers through hundred millions

Parent/Teacher Tips

The first several lessons in this unit review foundational concepts that students should have mastered in previous math levels. It is expected and appropriate that these lessons will be fairly easy for the child. These lessons may be finished in much less time than the lesson average.

Concepts Reviewed and Expanded Upon

-  addition (three or more addends)
-  addition/subtraction (multi-digit, money)
-  angle classifications
-  commutative property of addition
-  conversion (units of length)
-  division (arrays, equal groups)
-  elapsed time beyond 1 hour
-  expanded form through hundred millions
-  fact families and inverse operations
-  fractions and mixed numbers
-  fractions equal to one-half and one
-  geometric figures and polygons
-  mental math (addition and subtraction)
-  multiplication
-  number patterns
-  place value through billions
-  round whole numbers to billions
-  scales
-  solving for unknowns
-  subtraction across zeros
-  time

SOLVING FOR UNKNOWNNS

Complete today's Math 4 Mental Math Map Mysteries activity.

Watch the video lesson and/or read the mini lesson.

Video Lesson

Scan the QR code or watch the video lesson on goodandbeautiful.com/Math4. The section below is used during the video.

$$c + 9 = 15$$

$$19 - d = 7$$



Mini Lesson

An **unknown** is a number in an equation that we don't know. An unknown can be shown as a blank space or shape but most often is represented by a letter. Often unknowns can be found using the opposite, or inverse, operation from the one found in the equation. An **operation** is a mathematical process. The four basic operations in math are addition, subtraction, multiplication, and division. **Inverse operations** are operations that undo each other.

Inverse Operations

Addition & Subtraction

Multiplication & Division

In an addition equation, subtraction can be used to find the unknown number.

Addition Equation	Use the Inverse Operation	Solve for Unknown
$A + 7 = 18$	$18 - 7 = A$	$A = 11$

Another way to find unknowns is to use fact families. A **fact family** is a group of math facts, or equations, that use the same set of three numbers. Different equations within a fact family can help solve for an unknown. The circled equation in the fact family listed can help solve for the unknown in the original equation.

Fact Family		
	$11 - B = 5$	
Equation	$5 + B = 11$	Solve for Unknown
$11 - B = 5$	$B + 5 = 11$	$B = 6$
	$11 - 5 = B$	

An unknown can be shown as a blank space or shape, but most often it is represented by a letter.

Lesson Practice

MATH MYSTERIES

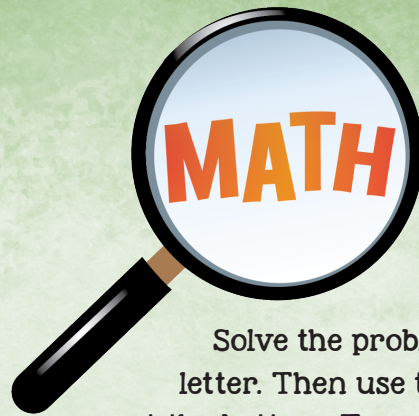

Solve the problems below to find the answer for each unknown letter. Then use those letters and their values to answer the riddle at the bottom. Try using inverse operations to solve the problems!



$8 + T = 20$ $T = \underline{\quad}$	$B - 7 = 6$ $B = \underline{\quad}$	$M - 10 = 15$ $M = \underline{\quad}$	$A + 8 = 16$ $A = \underline{\quad}$	$12 + P = 23$ $P = \underline{\quad}$
$E - 13 = 5$ $E = \underline{\quad}$	$16 + S = 22$ $S = \underline{\quad}$	$F - 15 = 15$ $F = \underline{\quad}$	$5 + E = 19$ $E = \underline{\quad}$	$T + 4 = 11$ $T = \underline{\quad}$
$H - 8 = 7$ $H = \underline{\quad}$	$14 + N = 24$ $N = \underline{\quad}$	$R - 1 = 8$ $R = \underline{\quad}$	$O + 9 = 12$ $O = \underline{\quad}$	$V - 2 = 20$ $V = \underline{\quad}$

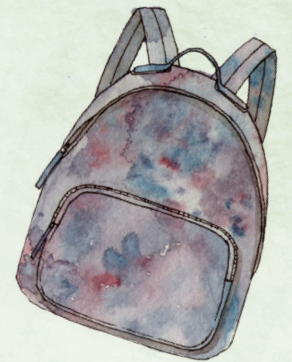

People lose me more than any other item. What am I?

8 7 22 9 14 25 3 12 18

Review

1. Write a fact family for each set of numbers. Each fact family has two addition equations and two subtraction equations.

3, 9, 12

5, 8, 13

9, 13, 22

2. Circle the numbers on the number lines that follow the pattern of skip counting by 4s.

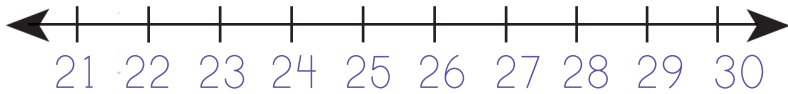
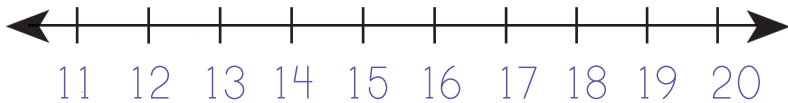
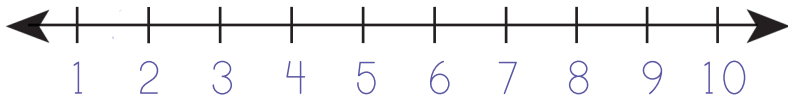

3. On the number lines above, put an X on the numbers that follow the pattern of skip counting by 3s. Which numbers have both a circle and an X?

4. Your mom is trying to decide if she wants to make pumpkin pie or apple pie for dessert on Thanksgiving. You volunteer to ask everyone in your entire family which type of pie he or she prefers. You talk to all 23 people who are coming. If 17 of them choose apple pie and the rest choose pumpkin pie, how many people choose pumpkin pie? Show your work in the box to the right.

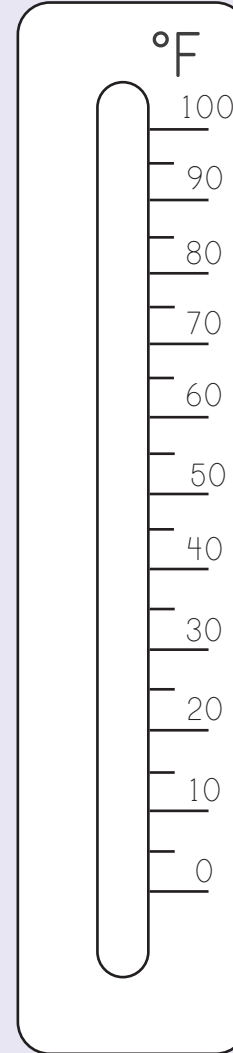
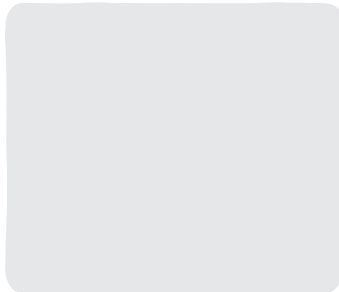

5. Shade the thermometer to show 55 °F.

6. What is the eleventh month of the year?

7. Multiply.

$$\begin{array}{r} 5 \quad 2 \\ \times 0 \quad \times 4 \\ \hline \end{array}$$

$$\begin{array}{r} 6 \quad 0 \\ \times 1 \quad \times 4 \\ \hline \end{array}$$

$$\begin{array}{r} 2 \quad 4 \\ \times 8 \quad \times 1 \\ \hline \end{array}$$

$$\begin{array}{r} 7 \quad 5 \\ \times 0 \quad \times 4 \\ \hline \end{array}$$

FRACTIONS

- Complete today's *Math 4 Mental Math Map Mysteries* activity.
- Watch the video lesson and/or read the mini lesson.

Video Lesson

Scan the QR code or watch the video lesson on goodandbeautiful.com/Math4. The section below is used during the video.

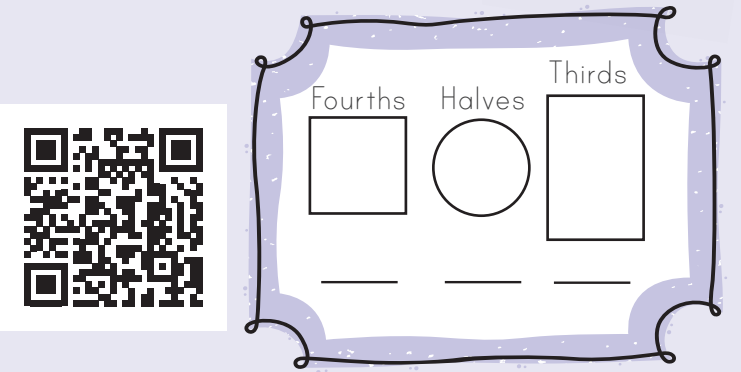
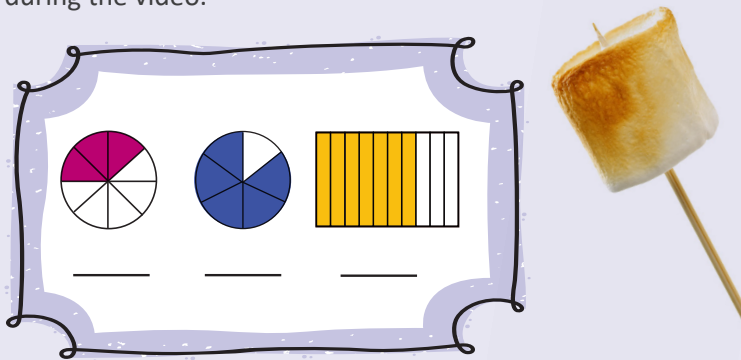

Mini Lesson

A **fraction** is a part or multiple parts of a whole. Fractions can be shown using different shapes. Circles, rectangles, and squares are most commonly used to show fractions.

Every fraction has a numerator and a denominator. The **numerator** is the top number in a fraction. It is the number of parts being referred to in a fraction. The **denominator** is the bottom number in a fraction. It is the total number of equal parts that make a whole.

Numerator

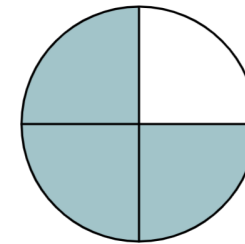
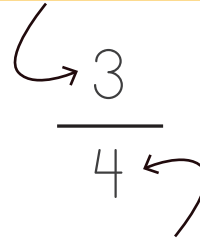

The fraction for this picture has four equal parts that make a whole. The denominator for this fraction is 4. Three of the parts are shaded, so the numerator is 3 if we are finding the fraction of the circle that is shaded. We read this fraction as three-fourths and write it using a fraction bar.

Denominator

Wholes can be divided equally in different ways. The greater the number in the denominator, the smaller the equal parts appear in a whole. Both shapes shown below are the same in size.

$$\frac{1}{3}$$

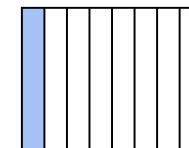
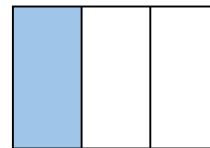

$$\frac{1}{8}$$

The whole on the left is divided into thirds. There are only three equal-sized parts in the whole, so the pieces are larger in size. The whole on the right is divided into eighths. Since there are eight equal-sized parts in this whole, the pieces are smaller.

Continued on the next page



You will write many different fractions in this course. They include halves, thirds, fourths, fifths, sixths, eighths, tenths, and twelfths.

Halves	Thirds	Fourths
Fifths	Sixths	
Eighths	Tenths	Twelfths

Fractions that have the same numerator and denominator are equal to one whole.

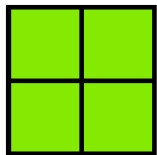

$$\frac{4}{4} = 1$$

Lesson Practice

1. Write the fraction for the shaded part of each of the shapes.

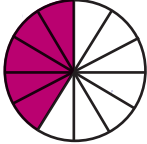
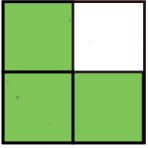

2. Shade in parts of the shapes to match the fractions listed.

$\frac{3}{5}$ 
 $\frac{2}{3}$ 
 $\frac{2}{4}$ 
 $\frac{6}{8}$ 

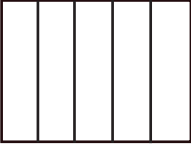
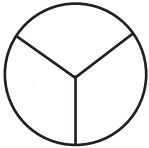
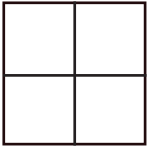
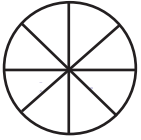
3. Fill in the blanks. *Need help? Refer to the mini lesson if you get stuck.*

The _____ is the number of parts being referred to in a fraction and is the top number. The _____ is the total number of equal parts that make a _____ and is the bottom number.



4. Write a fraction that shows how many people in this family are roasting marshmallows. Then write a fraction that shows how many people are wearing red shirts.

5. Draw lines to divide each shape into the fractional amount listed.

Thirds

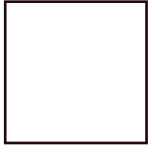

Eighths

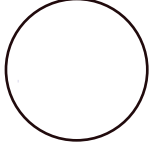

Fourths



Sixths

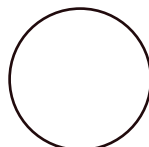

Halves

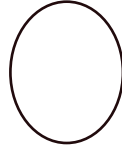

6. Divide and shade the shapes to show the indicated fractions.

$$\frac{1}{2}$$



$$\frac{2}{4}$$



$$\frac{4}{8}$$



$$\frac{1}{3}$$

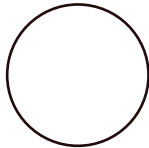

$$\frac{2}{6}$$

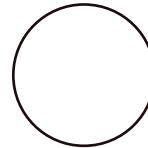

$$\frac{3}{3}$$

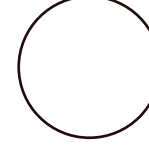

7. What fraction of the letters in the word MISSISSIPPI are the letter I? _____

8. What fraction of your family is younger than 14? _____

Read with your parent or teacher

You are now ready to take your first Multiplication Mastery Assessment. Have your parent or teacher quiz you on Multiplication Set A using the Multiplication Mastery Chart on page 395.

Parent/Teacher: Indicate which facts from Set A the student has mastered in the "Mastered" column on page 395. The student will continue to review and practice these facts throughout the course.

Review

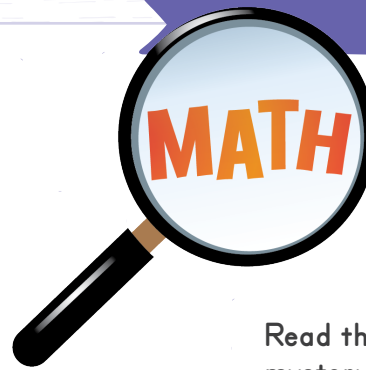

MYSTERIES

Who Am I?

Read the clues below to determine the mystery number.

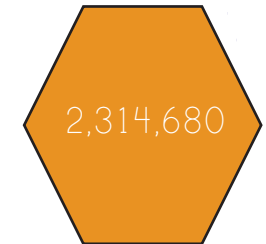
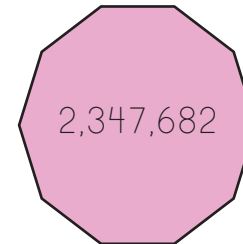
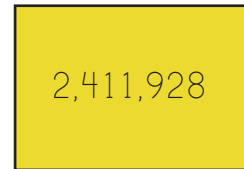
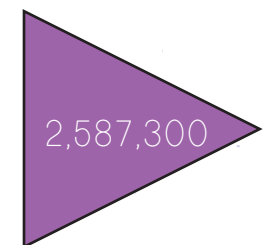
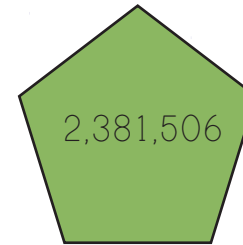
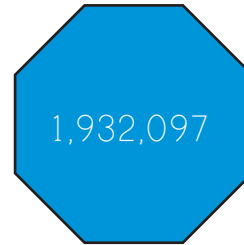

- ★ I am more than 2,000,000.
- ★ I am less than 2,500,000.
- ★ I have a 3 in the hundred thousands place.
- ★ Rounded to the nearest hundred thousand, I'm 2,300,000.
- ★ I am not inside the hexagon.
- ★ Who am I? _____

What is the name of the shape the mystery number is in?

ELAPSED TIME: START AND END TIMES

- Complete today's *Math 4 Mental Math Map Mysteries* activity.
- Watch the video lesson and/or read the mini lesson.

Video Lesson

Scan the QR code or watch the video lesson on goodandbeautiful.com/Math4. The section below is used during the video.

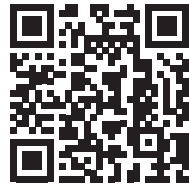

Elapsed Time:		Elapsed Time:	
Time	Interval	Time	Interval

Mini Lesson

When solving elapsed time problems, sometimes you are given the elapsed time and you need to figure out either the start or end time.

Steps to find the **END TIME**:

- Begin at the **START TIME** and count forward the number of hours listed in the **ELAPSED TIME**.
- Count forward the number of minutes listed in the **ELAPSED TIME**, and then you have the **END TIME**.

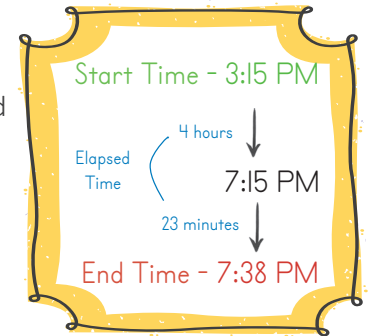

Steps to find the **START TIME**:

- Begin at the **END TIME** and count backward the number of hours listed in the **ELAPSED TIME**.
- Count backward the number of minutes listed in the **ELAPSED TIME**, and then you have the **START TIME**.

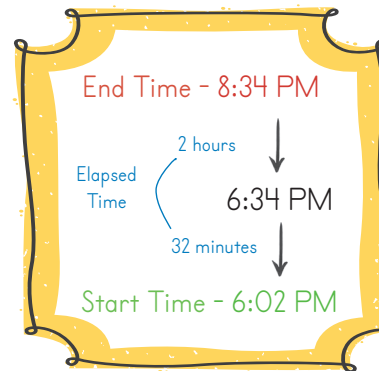

TIP: Use a T-Chart to help find the start or end time.

If given the start time and elapsed time, count forward.		If given the end time and elapsed time, count backward.	
Time	Interval	Time	Interval
1:52 PM	Start Time	9:16 PM	End Time
4:52 PM	3 hr	4:16 PM	5 hr
5:10 PM	18 min	3:49 PM	27 min
End Time	Elapsed Time	Start Time	Elapsed Time
ELAPSED TIME: 3 hours 18 min		ELAPSED TIME: 5 hours 27 min	

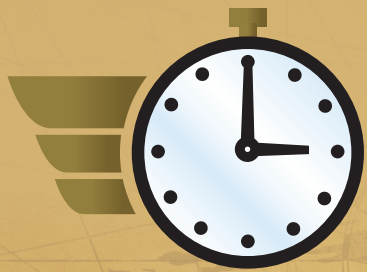

TRAVELING Through **TIME**

Tour famous locations around the world as you use the elapsed times listed on this map to answer the questions in the practice section.



Grand Canyon,
Arizona,
USA

6 hr 17 min



Machu Picchu,
Peru

10 hr 34 min



Matterhorn,
Switzerland

Great Pyramid
of Giza, Egypt



8 hr 49 min

Taj Mahal,
India



8 hr 13 min



Great Wall
of China

5 hr 21 min



Great
Barrier Reef,
Australia

7 hr 6 min



Victoria Falls,
Zambia

9 hr 42 min

Lesson Practice

Your vacation starts in the US state of Arizona at the Grand Canyon, one of the most popular tourist sites in the world. From there you fly to Peru. Your flight leaves at 3:28 PM. What time will you arrive?



After touring Machu Picchu, which is perched on a mountain at 7,000 feet in elevation, you board a plane to fly to Switzerland. You arrive in Switzerland at 11:51 PM. What time did your flight leave?

After standing in the shadow of the mighty Matterhorn, it's time to continue on to China. Your plane takes off at 2:42 AM. What time will you arrive?



Standing on the Great Wall of China, which is more than 2,000 years old, was amazing. Now you are off to Australia. You arrive at 9:34 PM. What time did your flight leave?

After snorkeling in the Great Barrier Reef, you have a choice to make. Will the last stop on your trip be the Taj Mahal in India, the Great Pyramid of Giza in Egypt, or Victoria Falls in Zambia? You choose! Your flight leaves at 1:06 AM. What time will you arrive at your last stop?



Review

1. Complete the problems.

$$\begin{array}{r} 800,000,000 \\ - 378,346,917 \\ \hline \end{array}$$

$$\begin{array}{r} 346,702,647 \\ + 276,671,507 \\ \hline \end{array}$$

2. Round the numbers to the nearest ten million and estimate the answer. Then complete the problem to see how close the estimate is.

$$\begin{array}{r} 46,393,753 \\ + 23,723,066 \\ \hline \end{array}$$

3. Compare the numbers and fill in the $<$, $>$, or $=$ symbol.

$1,357,875 \quad 1,357,695$

$37,671,204 \quad 37,678,374$

Targeted Multiplication Fact Practice

Practice any problems you missed in your Set B quiz in Lesson 23. Then complete the problems.

$\begin{array}{r} 7 \\ \times 8 \\ \hline \end{array}$	$\begin{array}{r} 4 \\ \times 4 \\ \hline \end{array}$	$\begin{array}{r} 9 \\ \times 5 \\ \hline \end{array}$	$\begin{array}{r} 5 \\ \times 8 \\ \hline \end{array}$	$\begin{array}{r} 5 \\ \times 4 \\ \hline \end{array}$	$\begin{array}{r} 4 \\ \times 9 \\ \hline \end{array}$	$\begin{array}{r} 3 \\ \times 7 \\ \hline \end{array}$	$\begin{array}{r} 8 \\ \times 7 \\ \hline \end{array}$
--	--	--	--	--	--	--	--

$\begin{array}{r} 9 \\ \times 3 \\ \hline \end{array}$	$\begin{array}{r} 4 \\ \times 5 \\ \hline \end{array}$	$\begin{array}{r} 7 \\ \times 3 \\ \hline \end{array}$	$\begin{array}{r} 4 \\ \times 7 \\ \hline \end{array}$	$\begin{array}{r} 3 \\ \times 9 \\ \hline \end{array}$	$\begin{array}{r} 9 \\ \times 4 \\ \hline \end{array}$	$\begin{array}{r} 7 \\ \times 4 \\ \hline \end{array}$	$\begin{array}{r} 8 \\ \times 5 \\ \hline \end{array}$
--	--	--	--	--	--	--	--

Lesson
27

ADDING THREE OR MORE ADDENDS

Supplies
12-inch ruler

Mini Lesson

- Complete today's *Math 4 Mental Math Map Mysteries* activity.
- Watch the video lesson and/or read the mini lesson.

Video Lesson

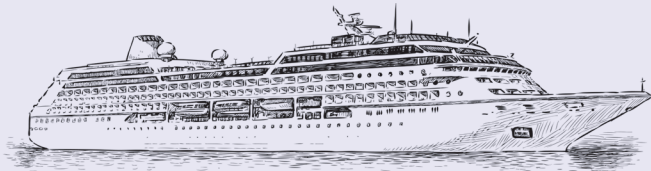

Scan the QR code or watch the video lesson on goodandbeautiful.com/Math4. This section is used during the video.

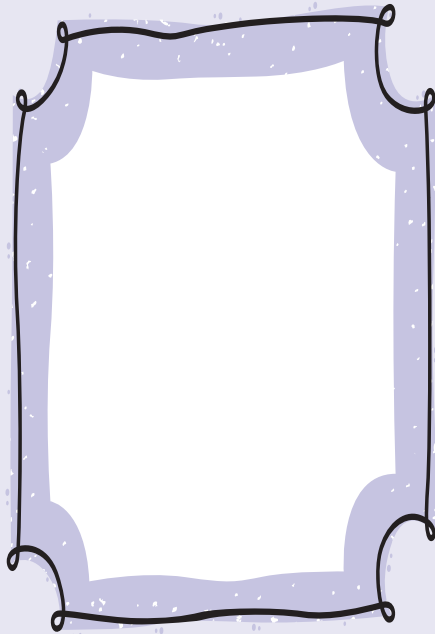
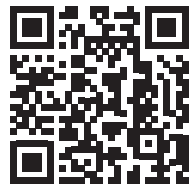

When finding the sum of numbers with three or more addends, we begin by adding the digits on the right and working our way to the left. If the sum of the digits in a column is a two-digit number, we write the first digit above the column to the left and the second digit below the line.

$$\begin{array}{r} 11 \\ 1,265 \\ 3,448 \\ + 201 \\ \hline 4,914 \end{array}$$

- Add the ones. $5 + 8 + 1 = 14$ [Write 4, Carry 1]
- Add the tens. $1 + 6 + 4 + 0 = 11$ [Write 1, Carry 1]
- Add the hundreds. $1 + 2 + 4 + 2 = 9$
- Add the thousands. $1 + 3 = 4$

We follow the same process no matter the number of digits in each addend.

$$\begin{array}{r} 11 \\ 305,914 \\ 72,180 \\ + 632 \\ \hline 378,726 \end{array}$$

- Add the ones. $4 + 0 + 2 = 6$
- Add the tens. $1 + 8 + 3 = 12$ [Write 2, Carry 1]
- Add the hundreds. $1 + 9 + 1 + 6 = 17$ [Write 7, Carry 1]
- Add the thousands. $1 + 5 + 2 = 8$
- Add the ten thousands. $0 + 7 = 7$
- Add the hundred thousands. $3 = 3$

If the sum of the digits in the last column is a two-digit number and there is not a column on the left to carry over to, we write the two-digit number below the line.

$$\begin{array}{r} 11 \\ 98,124 \\ 31,145 \\ + 4,810 \\ \hline 134,079 \end{array}$$

- Add the ones. $4 + 5 + 0 = 9$
- Add the tens. $2 + 4 + 1 = 7$
- Add the hundreds. $1 + 1 + 8 = 10$ [Write 0, Carry 1]
- Add the thousands. $1 + 8 + 1 + 4 = 14$ [Write 4, Carry 1]
- Add the ten thousands. $1 + 9 + 3 = 13$ [Write 13]

Day 1

On the first day of your family road trip, you left your house and traveled 87 miles to a waterfall, 22 miles to the mountains, and 104 miles to see a beautiful church. How far did you travel the first day?

Day 2

The next day you traveled 53 miles, stopped for ice cream, and then traveled 38 more miles to ride a roller coaster. Later, you traveled 126 miles and crossed a stone bridge and then drove another 219 miles to see a red rock canyon. How far did you travel on the second day of your trip?

Day 3

On Day 3 you took the scenic route through the canyon for 291 miles. Then you drove 334 miles and stopped for a picnic in a field of wildflowers before driving 45 miles to a hotel with a swimming pool. How far did you travel on Day 3?

Day 4

On Day 4 you drove 86 miles to have breakfast in a park before driving 176 miles to the museum. That afternoon you drove to the zoo, 131 miles away, before finally traveling the last 24 miles to the beach. How far did you travel on Day 4?

Day 5

Your vacation is over; it's time to drive home.

Optional challenge question: How many total miles is it from your house to the beach?

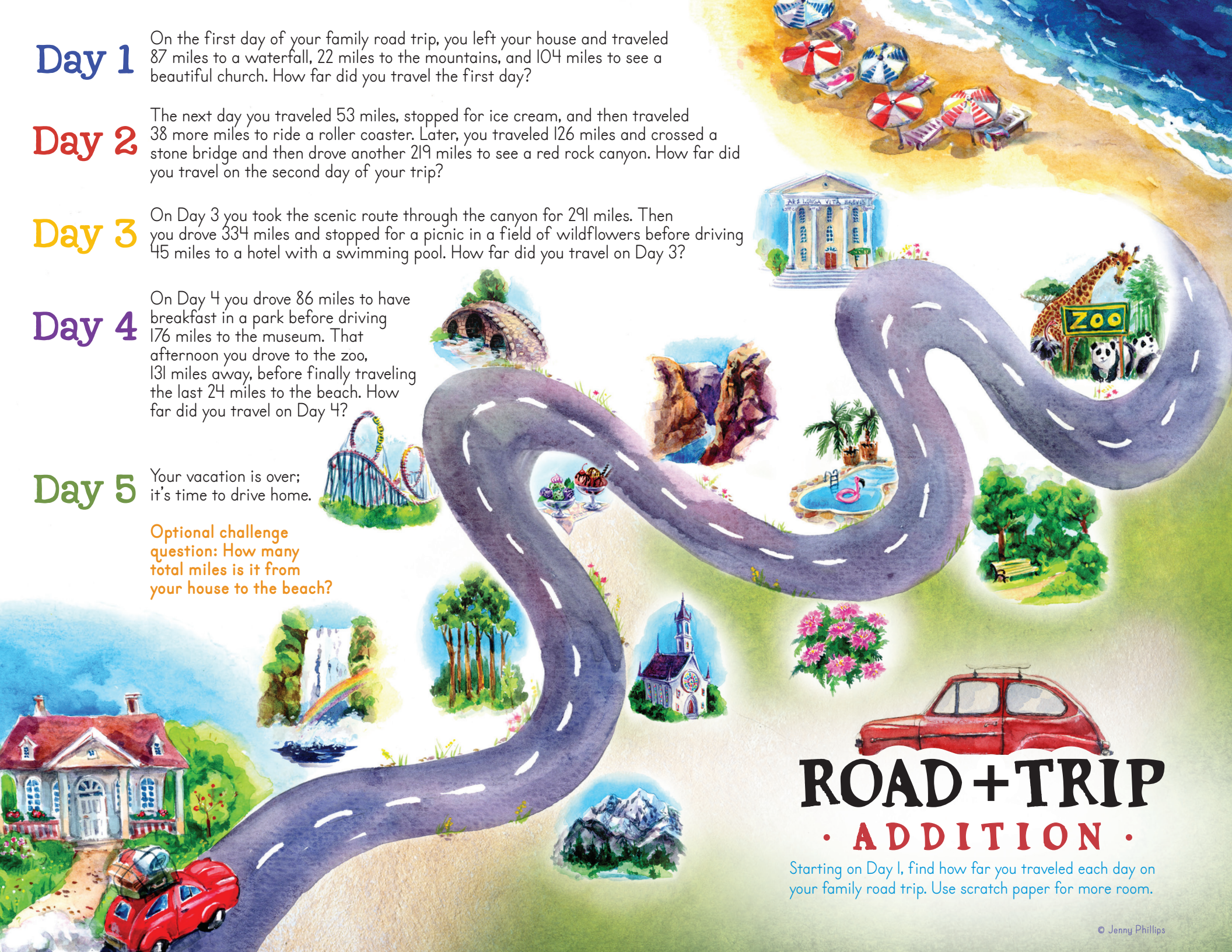

ROAD + TRIP

• ADDITION •

Starting on Day 1, find how far you traveled each day on your family road trip. Use scratch paper for more room.

UNIT ASSESSMENT

Parent/Teacher

Supplies
12-inch ruler

 **Read the following information aloud to the child:** Unit assessments give you practice with the mathematical concepts learned in this course without having you overpractice concepts that you have mastered. These assessments also give you practice working on exercises for an extended period of time. This helps you to extend your focus and attention span and to be better prepared for any type of testing you will have to do in the future.

 Here are some tips. First, make sure to read the instructions carefully. Sometimes you can get answers wrong simply because you did not understand the instructions. Second, do not rush through exercises you think you already know. Instead, make sure to do your work carefully. And finally, if you feel you are having trouble focusing, take a quick break to do something else, like ten jumping jacks. There are no videos for Lessons 29–30.

 For Lesson 29 complete all the exercises with PURPLE headers ONLY. Your parent or teacher will correct the work. If you make one or more mistakes in a section, your parent or teacher will check the orange “Additional Practice” checkbox for that section.

 For Lesson 30 complete all the orange sections **that are checked**. If you still miss multiple problems, go back and rewatch the video or reread the mini lesson for that topic. All the principles will be reviewed again in future units. If you have only a few or no orange sections to practice, you may move on to the next unit.

Student

READING SCALES & MEASURING (LESSON 23)

1. Label the inch scale below with the missing half-inch and quarter-inch measurements.



2. Measure this line segment to the nearest quarter inch.



3. How long is the lollipop?



Additional Practice

1. Draw a line segment that is $2\frac{3}{4}$ inches long.
2. Measure the following line segment to the nearest inch.
 
3. Find an object in your house that measures between 3 inches and 4 inches. Show it to your parent or teacher.

ADDITION, SUBTRACTION & WRITING NUMBERS

(LESSONS 19 & 20)

1. Complete each problem.

$$\begin{array}{r} 7,000,000 \\ - 5,347,501 \\ \hline \end{array}$$

$$\begin{array}{r} 32,461,084 \\ + 41,372,407 \\ \hline \end{array}$$

$$\begin{array}{r} 172,681,364 \\ + 441,132,737 \\ \hline \end{array}$$

$$\begin{array}{r} 20,000,000 \\ - 8,274,391 \\ \hline \end{array}$$

2. Write the following numbers using digits.

Twenty-four million, six hundred seventy-two thousand, nine hundred thirty-one _____





Seven billion, three hundred nineteen million, nine hundred forty-six thousand, two hundred four _____

3. Write the following number using words.

357,618,452

Additional Practice

Use the chart to answer the following questions.

Object	Number
	48,304,971
	22,374,019
	60,000,000
	35,476,945

1. How many cacao beans are there? Write the number in word form.

2. How many rubber ducks and bees are there in total?

3. How many more bottles of milk are there than rubber ducks?

4. How many cacao beans and bees are there in total?

MULTIPLYING
(LESSONS 5 & 26)

$$\begin{array}{r} 3,193 \\ \times \quad 3 \\ \hline \end{array}$$

$$\begin{array}{r} 144 \\ \times \quad 2 \\ \hline \end{array}$$

$$\begin{array}{r} 3,425 \\ \times \quad 5 \\ \hline \end{array}$$

$$\begin{array}{r} 439 \\ \times \quad 4 \\ \hline \end{array}$$

$$\begin{array}{r} 6,072 \\ \times \quad 3 \\ \hline \end{array}$$

$$\begin{array}{r} 834 \\ \times \quad 2 \\ \hline \end{array}$$

$$\begin{array}{r} 3,492 \\ \times \quad 9 \\ \hline \end{array}$$

$$\begin{array}{r} 460 \\ \times \quad 6 \\ \hline \end{array}$$

Additional Practice

$$\begin{array}{r} 134 \\ \times \quad 2 \\ \hline \end{array}$$

$$\begin{array}{r} 362 \\ \times \quad 5 \\ \hline \end{array}$$

$$\begin{array}{r} 493 \\ \times \quad 4 \\ \hline \end{array}$$

$$\begin{array}{r} 271 \\ \times \quad 3 \\ \hline \end{array}$$

$$\begin{array}{r} 421 \\ \times \quad 2 \\ \hline \end{array}$$

$$\begin{array}{r} 1,204 \\ \times \quad 2 \\ \hline \end{array}$$

$$\begin{array}{r} 3,641 \\ \times \quad 4 \\ \hline \end{array}$$

$$\begin{array}{r} 5,432 \\ \times \quad 5 \\ \hline \end{array}$$

$$\begin{array}{r} 7,260 \\ \times \quad 3 \\ \hline \end{array}$$

ANGLES
(LESSON 13)

Name the types of angles below.

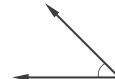

Look at each angle measurement and match it with the angle type. Some angle types will match more than one measurement.

22°

90°

141°

69°

180°

102°

acute

obtuse

right

straight

COMPARE, ORDER & ESTIMATE NUMBERS (LESSONS 22 & 24)

1. Grace completed the problem below. Round both numbers to the nearest ten thousand and estimate the answer. Based on your estimation, is Grace's answer likely right or wrong?

$$\begin{array}{r} 913413 \\ 835,349 \\ - 344,917 \\ \hline 690,432 \end{array}$$

2. Order the numbers below from greatest (on top) to least.

347,287,104	
347,841,358	
347,231,985	
347,764,020	
347,234,765	

Additional Practice

1. Compare the two numbers and fill in the $<$, $>$, or $=$ symbol.

39,715,624 39,717,842 2,629,374 2,629,719

84,617,619 84,617,270 492,726,311 492,746,997

2,674,824 677,917 3,374,035 21,379,674

2. Round to the nearest hundred thousand and estimate the sum.

$$\begin{array}{r} 2,631,049 \\ + 1,282,437 \\ \hline \end{array}$$

FRACTIONS & MIXED NUMBERS (LESSONS 15 & 21)

1. Plot and label the following mixed numbers and fraction on the number line.

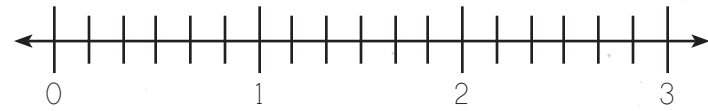

$A = 2\frac{3}{6}$ $B = 1\frac{5}{6}$ $C = \frac{1}{6}$

2. Divide and shade each shape to match the fraction listed.

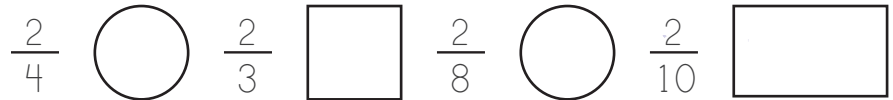

3. Draw a picture to represent the mixed number $4\frac{4}{6}$.

Additional Practice

1. Write the location of each point shown on the number line.

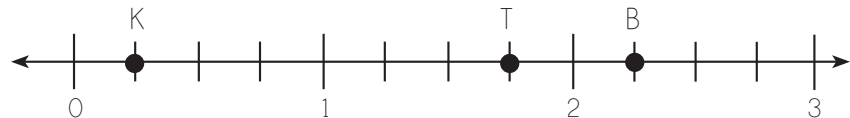



$B =$ $K =$ $T =$

2. Draw a picture to represent the mixed number $2\frac{1}{4}$.











UNIT 2 OVERVIEW

LESSONS 31-60

Extra Supplies Needed

-  ruler
-  measuring cups and large bowl
-  colored pencils or crayons

















New Concepts Taught

-  add/subtract fractions (uncommon denominators)
-  associative property of addition
-  associative property of multiplication
-  convert improper fractions to mixed numbers
-  divisibility rules for 2, 5, and 10
-  exponents
-  long division (one-digit divisors)
-  order of operations
-  perfect squares to 144
-  prime and composite numbers
-  triangle classification by angles

Parent/Teacher Tips

As students learn more advanced concepts, they may want to refer to the Reference Guide on page 394, especially when completing the Review sections. The Reference Guide has visuals and guides to help students practice and memorize certain concepts.

Concepts Reviewed and Expanded Upon

-  compare fractions
-  conversion (units of volume)
-  equivalent fractions
-  fractions of a set
-  graphs (pictographs, bar graphs, and line graphs)
-  lines of symmetry
-  missing factors
-  multiples and factors
-  multiplication by 100, 1,000, and 10,000
-  perimeter and area (rectangles, squares, and triangles)
-  problem solving with multiple steps
-  reflectional symmetry
-  rotational symmetry
-  similar and congruent shapes
-  temperature
-  triangle classifications by sides

SIMILAR AND CONGRUENT FIGURES

- Complete today's *Math 4 Mental Math Map Mysteries* activity.
- Watch the video lesson and/or read the mini lesson.

Video Lesson

Scan the QR code or watch the video lesson on goodandbeautiful.com/Math4.

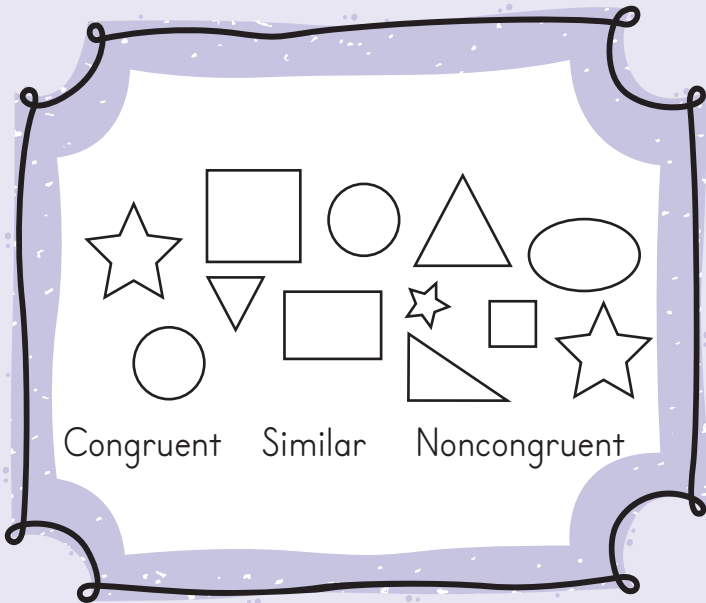
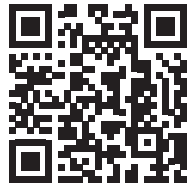

Mini Lesson

Congruent is a mathematical term that means having the same exact shape and size. Look at the three line segments shown here.

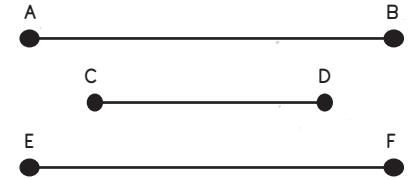

Line segment AB is congruent to line segment EF because they are the same size. Line segment CD is not congruent to the other two line segments because it is not the same size.

Two-dimensional (2D) figures are flat shapes with length and width but no depth. They can only be measured in two dimensions: length and width. Shapes can be categorized as congruent, noncongruent, or similar.

Congruent shapes are shapes with the exact same shape and size. If you put one congruent shape on top of another, they will align completely. Shapes that are not congruent are classified as noncongruent. Noncongruent shapes do not have the same shape and/or size.

Congruent

Same shape and size



Noncongruent

Different shape and/or size



Similar

Same shape

Similar means having the same shape but not necessarily the same size. Shapes that are similar are proportional to each other, which means you can shrink or stretch the shapes to be the same size.

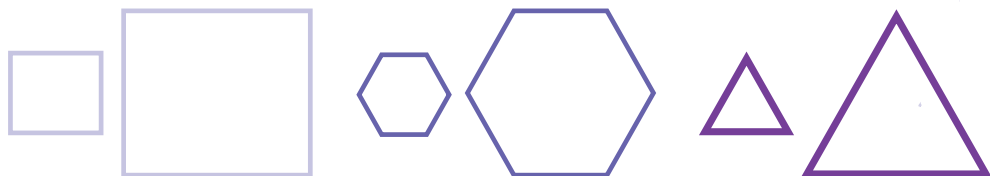

Lesson Practice

The ranch below has congruent and similar shapes hidden within the picture. Use the labeled shapes to answer the questions on the next page.

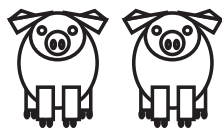
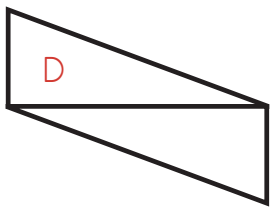
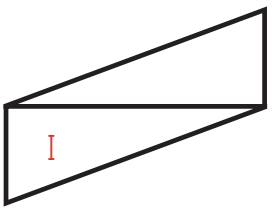
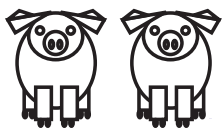
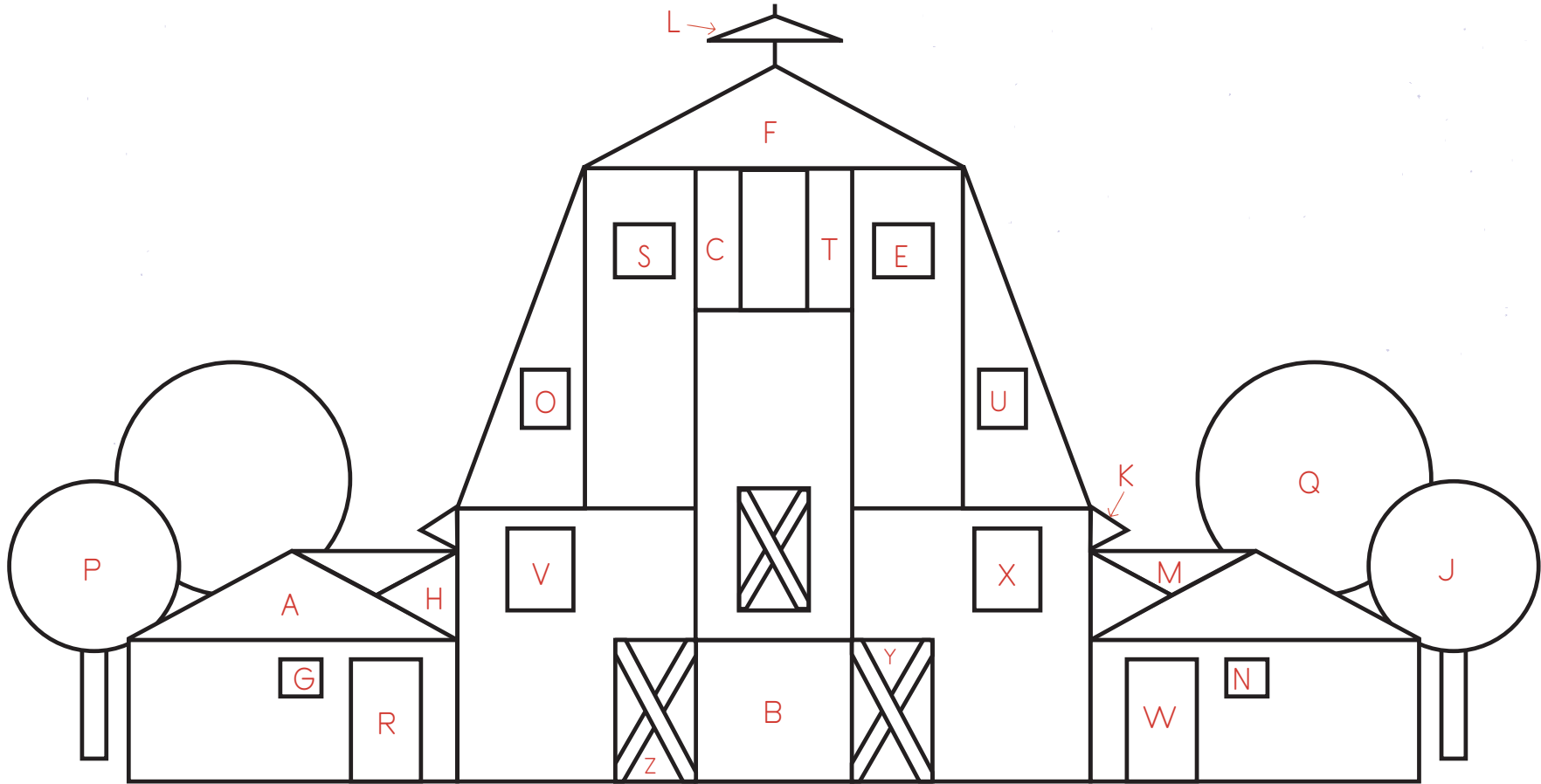

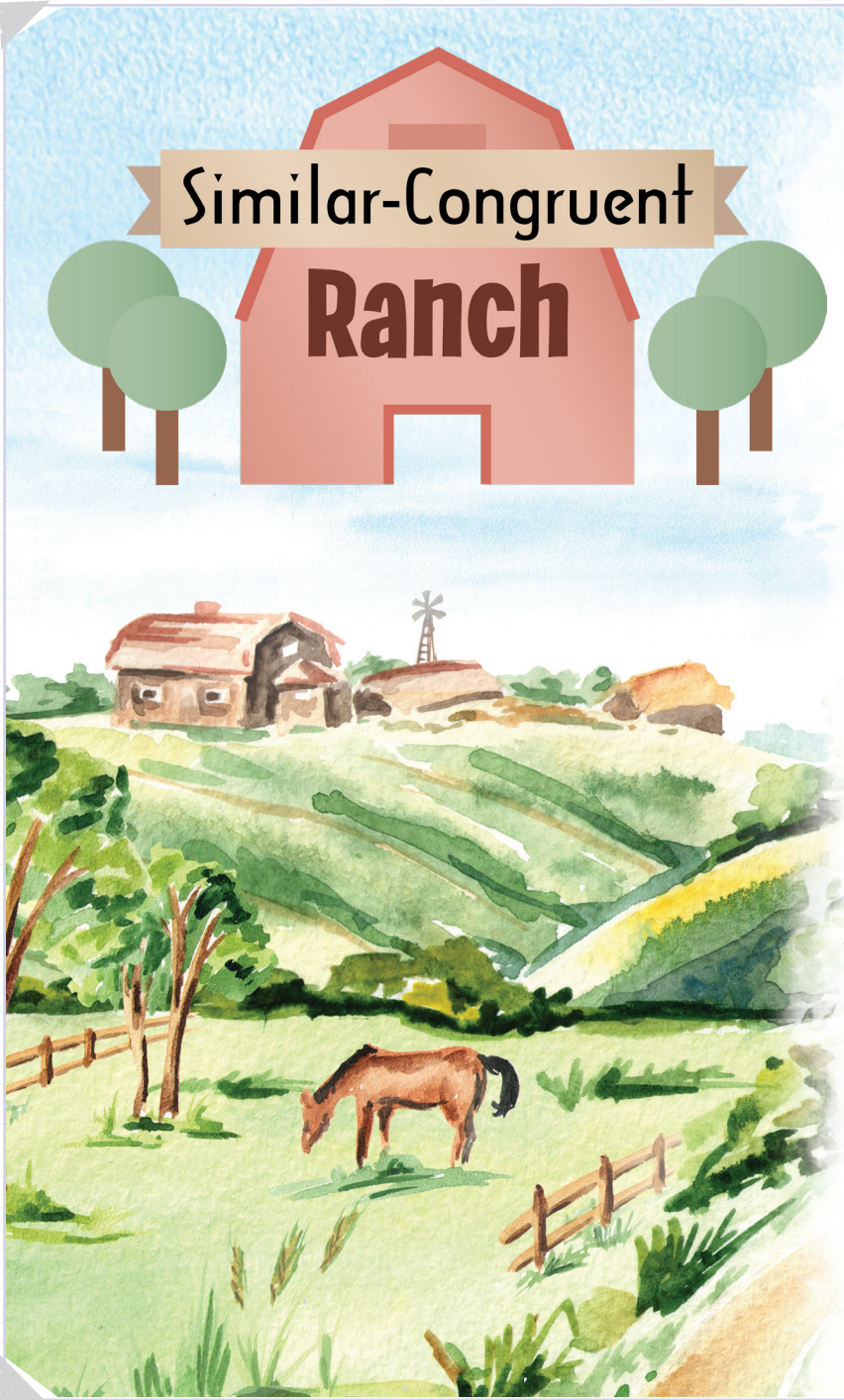

For each description below, write the answer on the line.

- Name one rectangle that is congruent to door R. _____
- Name two windows that are similar to B. _____
- Name one triangle congruent to triangle I. _____
- Which two triangles on the barn door are congruent? _____
- Name a circle that is congruent to J. _____
- How many shapes are congruent to D? _____
- Name two triangles similar to L. _____
- Are C and T congruent? _____
- Name two rectangles that are similar to V. _____
- Which rectangle is congruent to window S? _____
- Name two triangles that are similar to H. _____
- How many animals are congruent? What are they? _____
- Which rectangle is congruent to X? _____
- Are V and U congruent? _____
- How many shapes are similar to Q? _____

Optional Coloring Extension:

- Color triangles similar to triangle D brown.
- Color labeled rectangles black.
- Color any rectangles not labeled red.
- Color all similar circles green.
- Color triangles similar to triangles A and H black.
- Color remaining shapes any color you want.

EXPONENTS AND PERFECT SQUARES

- 📖 Complete today's *Math 4 Mental Math Map Mysteries* activity.
- 📺 Watch the video lesson and/or read the mini lesson.

Video Lesson

Scan the QR code or watch the video lesson on goodandbeautiful.com/Math4.

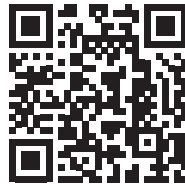

Exponent Form	Factored Form
9^3	
	$6 \times 6 \times 6 \times 6 \times 6$
10^4	

Exponent Form	Factored Form	Answer
2^2		
	8×8	
10^2		
	5×5	

Mini Lesson

When **adding** the same number over and over, also known as repeated addition, we can use multiplication instead.

$$3 + 3 + 3 + 3$$

How many times the number is added to itself $\rightarrow 4 \times 3 \leftarrow$ Number being added
4 groups of 3

When **multiplying** the same number over and over, we use exponents. An **exponent** is a number showing how many times to multiply the number by itself. The number being multiplied by itself is called the base number. The exponent is written as a smaller number to the top right of the base number.

Factored Form
 $3 \times 3 \times 3 \times 3$

Base $\rightarrow 3^4 \leftarrow$ Exponent
Exponent Form

When a base number has an exponent of 2, we say the number is squared. A **perfect square** is the product of a whole number multiplied by itself. When showing perfect squares using arrays, the shape created is always a square.

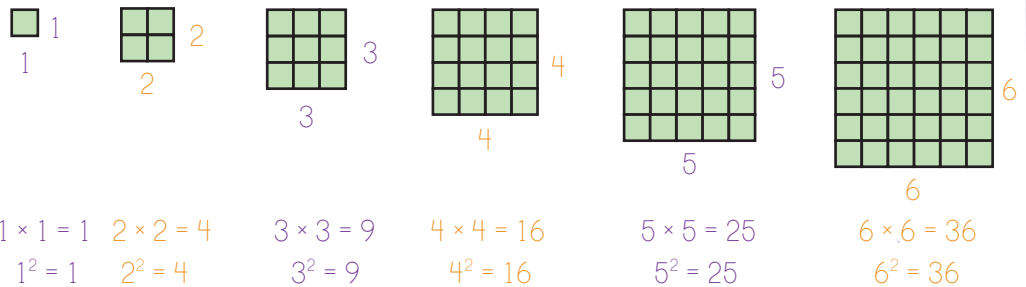

The numbers 1, 4, 9, 16, 25, and 36 are perfect squares.



Lesson Practice

1. Perfect squares make a pattern on a multiplication chart. Color in each perfect square from 1^2 to 12^2 . The numbers 4^2 (4×4) and 9^2 (9×9) have been done for you.

	1	2	3	4	5	6	7	8	9	10	11	12
1	1	2	3	4	5	6	7	8	9	10	11	12
2	2	4	6	8	10	12	14	16	18	20	22	24
3	3	6	9	12	15	18	21	24	27	30	33	36
4	4	8	12	16	20	24	28	32	36	40	44	48
5	5	10	15	20	25	30	35	40	45	50	55	60
6	6	12	18	24	30	36	42	48	54	60	66	72
7	7	14	21	28	35	42	49	56	63	70	77	84
8	8	16	24	32	40	48	56	64	72	80	88	96
9	9	18	27	36	45	54	63	72	81	90	99	108
10	10	20	30	40	50	60	70	80	90	100	110	120
11	11	22	33	44	55	66	77	88	99	110	121	132
12	12	24	36	48	60	72	84	96	108	120	132	144

2. Convert each problem from factored form to exponent form. The first one is given as an example.

$5 \times 5 \times 5 \times 5$ 5^4
 $1 \times 1 \times 1 \times 1 \times 1 \times 1$
 $12 \times 12 \times 12$
 7×7
 $3 \times 3 \times 3$

$2 \times 2 \times 2 \times 2 \times 2 \times 2 \times 2$
 10×10
 $6 \times 6 \times 6 \times 6 \times 6$
 $5 \times 5 \times 5 \times 5 \times 5 \times 5$

3. Fill in the missing information. The first row has been done for you.

Exponent Form	Factored Form	Answer
1^2	1×1	1
	2×2	
3^2		9
	4×4	
		25
	6×6	
7^2		
		64
	9×9	
10^2		
	11×11	
		144

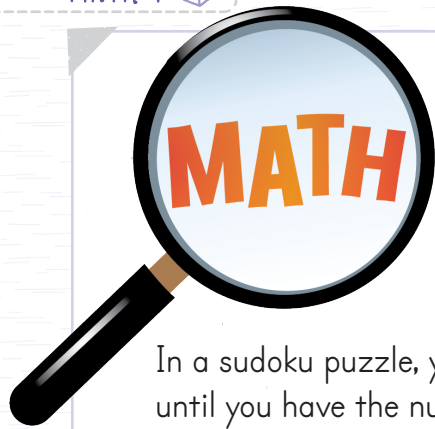

MYSTERIES

Sudoku

In a sudoku puzzle, you fill in the missing numbers until you have the numbers 1–9 in each block. Each number can only appear once in a row, column, or block. **TIP:** If a box has more than one possible option, skip it and come back to it after filling in more boxes.

	3		2	6	8	7		5
6	7	8	4	5		2		
1		2	9				4	
7	9	4			2	6	5	
			6	4	9	3		2
3		6		7	5		9	4
		3	7	9	6	4		
2	4		5	8		9		7
	6	7				5	8	3

Complete each problem.

$$\begin{array}{r} 1,328 \\ \times 6 \\ \hline \end{array}$$

$$\begin{array}{r} 371 \\ \times 4 \\ \hline \end{array}$$

$$\begin{array}{r} 4,307 \\ \times 2 \\ \hline \end{array}$$

$$\begin{array}{r} 971 \\ \times 3 \\ \hline \end{array}$$

$$\begin{array}{r} 2,544 \\ \times 7 \\ \hline \end{array}$$



Targeted Multiplication Fact Practice

Practice any problems you missed in your Set C quiz in Lesson 34. Then complete the problems in this section.

$$\begin{array}{r} 5 \\ \times 6 \\ \hline \end{array}$$

$$\begin{array}{r} 11 \\ \times 7 \\ \hline \end{array}$$

$$\begin{array}{r} 3 \\ \times 6 \\ \hline \end{array}$$

$$\begin{array}{r} 8 \\ \times 9 \\ \hline \end{array}$$

$$\begin{array}{r} 9 \\ \times 1 \\ \hline \end{array}$$

$$\begin{array}{r} 6 \\ \times 5 \\ \hline \end{array}$$

$$\begin{array}{r} 9 \\ \times 7 \\ \hline \end{array}$$

$$\begin{array}{r} 9 \\ \times 10 \\ \hline \end{array}$$

$$\begin{array}{r} 3 \\ \times 8 \\ \hline \end{array}$$

$$\begin{array}{r} 6 \\ \times 3 \\ \hline \end{array}$$

$$\begin{array}{r} 4 \\ \times 1 \\ \hline \end{array}$$

$$\begin{array}{r} 6 \\ \times 8 \\ \hline \end{array}$$

$$\begin{array}{r} 11 \\ \times 2 \\ \hline \end{array}$$

$$\begin{array}{r} 7 \\ \times 6 \\ \hline \end{array}$$

$$\begin{array}{r} 6 \\ \times 7 \\ \hline \end{array}$$

$$\begin{array}{r} 7 \\ \times 7 \\ \hline \end{array}$$

$$\begin{array}{r} 8 \\ \times 6 \\ \hline \end{array}$$

$$\begin{array}{r} 7 \\ \times 9 \\ \hline \end{array}$$

$$\begin{array}{r} 9 \\ \times 9 \\ \hline \end{array}$$

$$\begin{array}{r} 8 \\ \times 3 \\ \hline \end{array}$$

$$\begin{array}{r} 5 \\ \times 3 \\ \hline \end{array}$$

$$\begin{array}{r} 7 \\ \times 4 \\ \hline \end{array}$$

$$\begin{array}{r} 6 \\ \times 9 \\ \hline \end{array}$$

$$\begin{array}{r} 5 \\ \times 7 \\ \hline \end{array}$$

$$\begin{array}{r} 1 \\ \times 6 \\ \hline \end{array}$$

$$\begin{array}{r} 7 \\ \times 0 \\ \hline \end{array}$$

$$\begin{array}{r} 10 \\ \times 6 \\ \hline \end{array}$$

$$\begin{array}{r} 8 \\ \times 2 \\ \hline \end{array}$$

$$\begin{array}{r} 7 \\ \times 5 \\ \hline \end{array}$$

$$\begin{array}{r} 9 \\ \times 6 \\ \hline \end{array}$$

$$\begin{array}{r} 4 \\ \times 5 \\ \hline \end{array}$$

$$\begin{array}{r} 9 \\ \times 8 \\ \hline \end{array}$$

ORDER OF OPERATIONS

- Complete today's *Math 4 Mental Math Map Mysteries* activity.
- Watch the video lesson and/or read the mini lesson.

Video Lesson

Scan the QR code or watch the video lesson on goodandbeautiful.com/Math4.

$$4 \times (2 + 5)$$

do first
↓

$$15 - 3^2$$

do first
↓

$$24 \div (3 + 1) - 2^2 =$$



Mini Lesson

The **order of operations** is a set of rules that states the order in which to perform mathematical operations. The correct order is shown here. To help remember the correct order, we can use this phrase below:

1. Parentheses
2. Exponents
3. Multiply and Divide (from left to right)
4. Add and Subtract (from left to right)



The first letter of each word represents a step in the order of operations. The letter “P” is for parentheses, and “E” stands for exponents. “M” and “D” are for multiplication and division, and “A” and “S” mean addition and subtraction.

When simplifying a problem, we start with operations inside parentheses. In the purple box, $2 + 5$ is inside the parentheses and is done first. The sum is 7.

Next, we look for any exponents. Exponents tell us how many times a number is multiplied by itself. The number 3^2 is 3×3 , which is 9.

Then we look for multiplication and division. We multiply and divide from left to right. Whichever operation appears first in the problem is done first. The multiplication fact 7×9 is 63.

Finally, we add and subtract, again moving from left to right. The subtraction problem $63 - 3$ is 60. After following the order of operations, we find the problem $(2 + 5) \times 3^2 - 3$ simplifies to 60.

If we are simplifying a problem that does not have parentheses, we move to the next step. Think of it as a checklist. If a step is not found in the problem, cross it off and move to the next step.

$$\begin{array}{r}
 (2 + 5) \times 3^2 - 3 \\
 \text{Parentheses} \swarrow \searrow \\
 7 \times 3^2 - 3 \\
 \text{Exponents} \quad | \\
 7 \times 9 - 3 \\
 \text{Multiply and Divide} \swarrow \searrow \\
 63 - 3 \\
 \text{Add and Subtract} \swarrow \searrow \\
 60
 \end{array}$$

Lesson Practice



Snowing SOLUTIONS

1. Mathematical operations must be performed in a certain order. Write the following operations in the correct order in the box below.

ADD & SUBTRACT PARENTHESES MULTIPLY & DIVIDE EXPONENTS

1. _____

2. _____

3. _____

4. _____

2. If one operation is not present in a problem, skip it and go to the next operation. In the problem $3 + 4 \times 7$, there are no **parentheses** or **exponents**, so you would skip those steps and go to the next. **Multiplication** is the first step in this example. For each problem below, write which step you would complete first using the order of operations.

$(4 + 2) \times 4^2 - 1 =$

$4 - 2 + 1 =$

$4 + 2 \times 4^2 - 1 =$

$4 + 2 \times 3 - 1 =$

3. Write the phrase that can help you remember the order of operations.

P _____ E _____ M _____
 D _____ A _____ S _____

4. Complete each problem using the order of operations. Use scratch paper if you need more room. **Remember, if you have both multiplication and division or addition and subtraction in the same problem, you work from left to right.**

$10 - 4 + (5 \times 5) =$

$20 - (8 \times 2) =$

$(3 + 5) \div 2 =$

$5 \times (6 - 3) + 7 =$

$4^2 + (15 \div 3) =$

$6 \times 4 + 5 - 10 =$

$12 - (3 \times 2) + 2^2 =$

$2^2 \div 2 + (4 \times 1) =$

Review



1. Luis' family has a llama farm in the mountains of Peru. They bought five new llamas and are building a corral for them. Using the diagram, find how many feet of fencing they will need to build the new corral.
2. Luis knows that they need at least 2,000 sq ft of grass for the five new llamas. Is the new corral big enough? What is the area of the new corral?

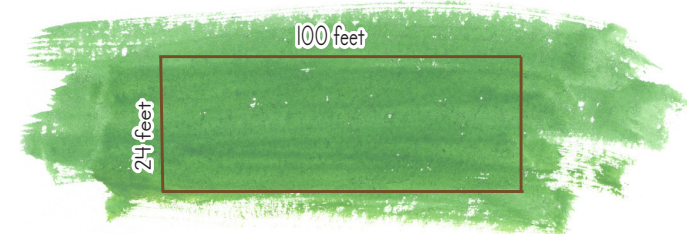

3. Find the congruent shapes and color each set the same color.

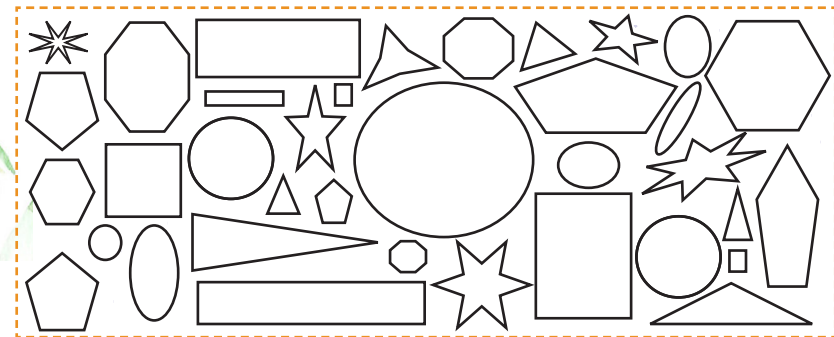

4. Which fraction is the greatest? Divide and shade the shapes to find out. Circle the greatest fraction.

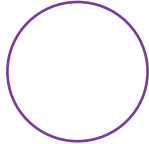

$$\frac{3}{4}$$

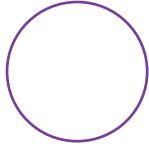

$$\frac{2}{3}$$

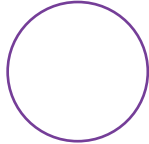

$$\frac{5}{6}$$

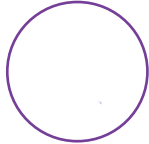

$$\frac{1}{2}$$

★ Read with your parent or teacher ★

It's time to take your next Multiplication Mastery Assessment. Have your parent or teacher quiz you on Multiplication Set C, using the Multiplication Mastery Chart on page 395.

Parent/Teacher: Indicate which facts from Set C the student has mastered in the "Mastered" column on page 395. Your student will continue to review and practice these facts throughout the course.

FACT FAMILY LOGIC

 Complete today's *Math 4 Mental Math Map Mysteries* activity.

This lesson does not have a video. Read through the mini lesson carefully, and then complete the assignment on the next page.

Mini Lesson

Fact Family for 5, 6, 11

$5 + 6 = 11$

$6 + 5 = 11$

$11 - 5 = 6$

$11 - 6 = 5$

A **fact family** is a group of math facts that uses the same three numbers to create two addition (or multiplication) equations and two subtraction (or division) equations.

You've learned about addition and subtraction fact families like this one on the left.

A fact family for multiplication and division uses a group of three numbers that are related through multiplication and division. You can create a fact family by starting with a multiplication fact. For example: $2 \times 5 = 10$.

Using the numbers 2, 5, and 10, we can create two multiplication facts and two division facts to complete our fact family.

Fact Family for 2, 5, 10

$2 \times 5 = 10$

$5 \times 2 = 10$

$10 \div 5 = 2$

$10 \div 2 = 5$



Crack the Cookie Code



Welcome to Milk & Cookies Bakery. Isaiah and his mother, Ruth, make fresh cookies each morning in preparation for the many customers who stop by for a sweet treat throughout the day.

Isaiah loves baking cookies with his mother. He especially loves when he gets to decorate the cookies and place them on the shelves. Sometimes customers will call in to order cookies for pickup. When Ruth is in the back baking cookies, she allows Isaiah to answer the phone and write down the orders.

On this particular morning, the phone rings constantly. Isaiah takes eight orders over the phone. He has to get the orders prepared quickly before the customers arrive to pick up their cookies.

Let's help Isaiah prepare the orders by completing the logic activity below.

Logic Activity

Remove the picture of the Milk & Cookies Bakery before starting this section. On the display shelves, there are 13 trays of cookies. Each type of cookie is labeled with a number. These numbers represent the numbers in specific multiplication and division fact families.

The orders listed on page 143 show eight different fact families. There are missing numbers in each of the fact families. Using the numbers already shown, complete the four facts in each fact family. Once you find the missing numbers, write the three numbers that make up that fact family on the blank spaces next to the words "Fact Family."

Each order placed over the phone has three different types of cookies. To find out which cookies go with each order, find the three numbers on the cookie trays that match the three numbers for each fact family. Using the color indicated on each order sheet, color the white circles next to the cookie tray numbers that match the fact family numbers for each order. The first one is done for you.



Order #1

$2 \times 6 = 12$

$6 \times 2 = 12$

$12 \div 2 = 6$

$12 \div 6 = 2$

Fact Family for 2, 6, 12

Order #2

___ x ___ = ___

___ x 2 = ___

___ ÷ ___ = 9

___ ÷ ___ = ___

Fact Family for ___, ___, ___

Order #3

5 x ___ = ___

___ x ___ = ___

___ ÷ ___ = ___

___ ÷ 12 = ___

Fact Family for ___, ___, ___

Order #4

___ x ___ = ___

___ x ___ = 12

___ ÷ 3 = ___

___ ÷ ___ = ___

Fact Family for ___, ___, ___

Order #5

10 x ___ = ___

___ x ___ = ___

___ ÷ 6 = ___

___ ÷ ___ = ___

Fact Family for ___, ___, ___

Order #6

___ x ___ = ___

12 x ___ = ___

___ ÷ ___ = 2

___ ÷ ___ = ___

Fact Family for ___, ___, ___

Order #7

___ x 6 = ___

___ x ___ = ___

30 ÷ ___ = ___

___ ÷ ___ = ___

Fact Family for ___, ___, ___

Order #8

3 x ___ = ___

___ x ___ = ___

___ ÷ ___ = ___

___ ÷ 8 = ___

Fact Family for ___, ___, ___

Isaiah wants to put the name of each customer on the correct bag of cookies. Use the alphabet code below to figure out the name of each customer he should write.

A	B	C	D	E	F	G	H	I	J	K	L	M	N	O	P	Q	R	S	T	U	V	W	X	Y	Z
1	2	3	4	5	6	7	8	9	10	11	12	13	14	15	16	17	18	19	20	21	22	23	24	25	26

1 ___ ___ ___
10 15 5

2 ___ ___ ___
12 5 5

3 ___ ___ ___
16 1 13

4 ___ ___ ___
10 5 14

5 ___ ___ ___
18 5 24

6 ___ ___ ___
1 13 25

7 ___ ___ ___
5 12 9

8 ___ ___ ___
19 1 13

TYPES OF TRIANGLES

- Complete today's *Math 4 Mental Math Map Mysteries* activity.
- Watch the video lesson and/or read the mini lesson.

Video Lesson

Scan the QR code or watch the video lesson on goodandbeautiful.com/Math4.

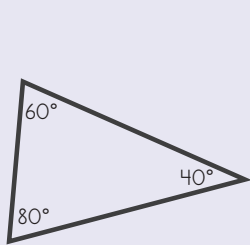
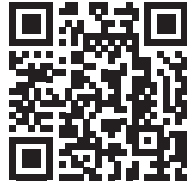



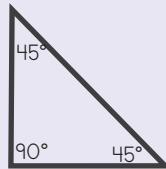

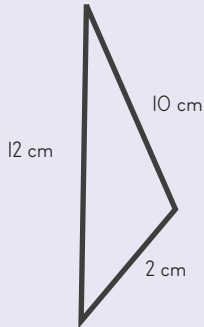

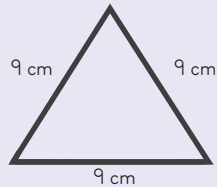

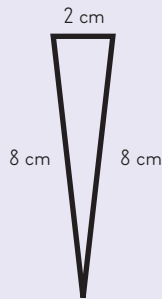

Mini Lesson

Two ways to classify a triangle are by the measures of its angles or by the lengths of its sides. Let's learn about both.

CLASSIFYING BY ANGLES

To classify a triangle by its angle measures, begin by looking at its angles. If a triangle has an angle that measures 90 degrees, which is often shown by a little square symbol, it is a **right triangle**. If it has an obtuse angle (between 90 and 180 degrees), it is an **obtuse triangle**. If all the angles are acute angles (less than 90 degrees), it is an **acute triangle**.

RIGHT TRIANGLE

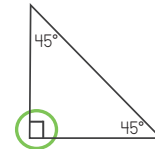

One right angle

OBTUSE TRIANGLE

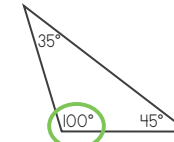

One obtuse angle

ACUTE TRIANGLE

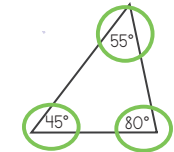

Three acute angles

CLASSIFYING BY SIDES

Another way to classify a triangle is by looking at its side lengths. If all three sides are of equal length, it is called an **equilateral triangle**. If two sides of a triangle are of equal length, it is called an **isosceles triangle**. If no sides are of equal length, it is called a **scalene triangle**.

EQUILATERAL TRIANGLE

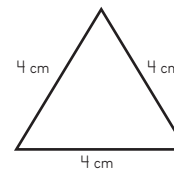

All sides of equal length

ISOSCELES TRIANGLE

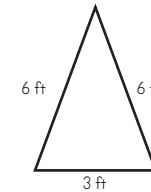

Two sides of equal length

SCALED TRIANGLE

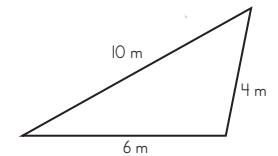

No sides of equal length

BUILDING BRIDGES

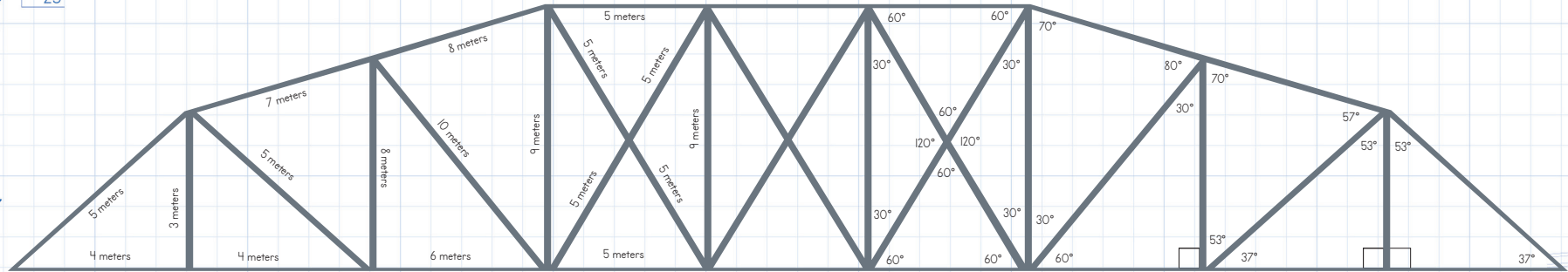

This bridge has many different types of triangles. The triangles on the left side of the bridge show side lengths. The triangles on the right side of the bridge show angle measures. Find each type of triangle described below and, using colored pencils, color one triangle on the bridge for each description. NOTE: Triangles may not be drawn to scale.

By Side

By Angle

This **SCALENE** triangle has two sides that measure 10 meters and 9 meters. Color this triangle **GREEN**.

This **ISOSCELES** triangle has two sides that measure 5 meters. Color this triangle **RED**.

This **ACUTE** triangle has an angle that measures 57° and an angle that measures 70° . Color this triangle **GREEN**.

This **RIGHT** triangle has an angle that measures 30° and an angle that measures 60° . Color this triangle **RED**.

This **EQUILATERAL** triangle has equal sides that measure 5 meters. Color this triangle **BLUE**.

This **SCALENE** triangle has two sides that measure 7 meters and 8 meters. Color this triangle **YELLOW**.

This **OBTUSE** triangle has an angle that measures 120° . Color this triangle **BLUE**.

This **ACUTE** triangle has three angles that measure 60° . Color this triangle **YELLOW**.

This **SCALENE** triangle has two sides that measure 6 meters and 8 meters. Color this triangle **ORANGE**.

This **ISOSCELES** triangle has two sides that measure 5 meters. Color this triangle **PURPLE**.

This **ACUTE** triangle has an angle that measures 80° and an angle that measures 30° . Color this triangle **ORANGE**.

This **RIGHT** triangle has an angle that measures 53° and an angle that measures 37° . Color this triangle **PURPLE**.

UNIT 3 OVERVIEW

LESSONS 61-90

Extra Supplies Needed

- ▮ 1 standard dice
- ▮ colored pencils or crayons

New Concepts Taught

- ▮ add/subtract decimals to the thousandths place
- ▮ change mixed numbers to improper fractions
- ▮ circles (center, radius, and diameter)
- ▮ distributive property
- ▮ find mixed numbers using long division
- ▮ geometric transformations
- ▮ long division (with remainders)
- ▮ long division (zero in the quotient)
- ▮ measuring turns
- ▮ multiplication (two-digit by two-digit)
- ▮ perimeter and area (irregular shapes)
- ▮ reducing fractions to simplest form
- ▮ tessellations (regular and semi-regular)
- ▮ volume of cubes
- ▮ volume of rectangular prisms

Concepts Reviewed and Expanded Upon

- ▮ conversion (units of length)
- ▮ geometric solids
- ▮ multiplication (multiples of 100, 1,000, and 10,000)
- ▮ naming geometric figures
- ▮ patterns
- ▮ quadrilateral classification
- ▮ Roman numerals

Parent/Teacher Tips

Students will complete multiplication facts in every lesson in Unit 3; however, they will not be prompted to practice the multiplication Sets A–D anymore. Memorizing these facts is vital. If the child is still struggling, consider continuing daily practice using *Musical Multiplication* or another method.

MULTIPLICATION: MULTIPLES OF 10

- Complete today's *Math 4 Mental Math Map Mysteries* activity.
- Watch the video lesson and/or read the mini lesson.

Video Lesson

Scan the QR code or watch the video lesson on goodandbeautiful.com/Math4.

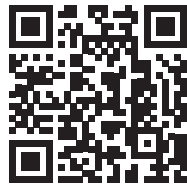

$$9 \times \$3,000 =$$

$$30 \times \$700 =$$

Mini Lesson

A **multiple** is the product of a number and an integer. Skip counting is one way to find the multiples of a number.

Multiples of 100
100, 200, 300, 400,
500, 600, 700,
800, 900, 1,000, ...

Multiples of 1,000
1,000, 2,000, 3,000,
4,000, 5,000, 6,000,
7,000, 8,000, ...

When multiplying a number by 10, 100, 1,000, or 10,000, multiply the 1 times the number, and then write the same number of zeros in the problem at the end.

$4 \times 10 = ?$	$4 \times 1,000 = ?$	$4 \times 10,000 = ?$
$4 \times 1 = 4$	$4 \times 1 = 4$	$4 \times 1 = 4$
$4 \times 10 = 40$	$4 \times 1,000 = 4,000$	$4 \times 10,000 = 40,000$

The same strategy can be used when multiplying by multiples of 10, 100, 1,000, or 10,000. Instead of multiplying the number by 1, multiply by all the digits that are NOT zero. Then write the number of zeros in the problem at the end.

$40 \times 300 = ?$	$5 \times 4,000 = ?$	$2 \times 40,000 = ?$
$4 \times 3 = 12$	$5 \times 4 = 20$	$2 \times 4 = 8$
$40 \times 300 = 12,000$	$5 \times 4,000 = 20,000$	$2 \times 40,000 = 80,000$

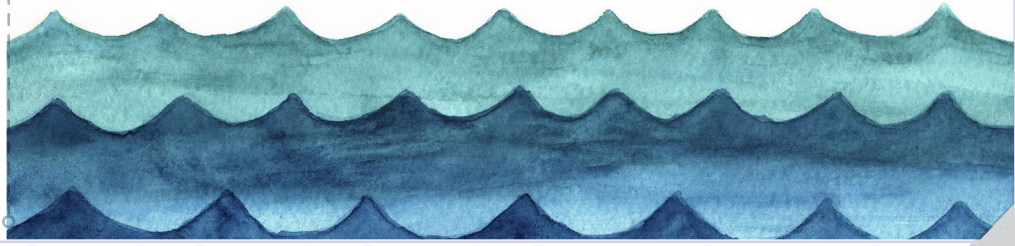

MAXED OUT

MULTIPLICATION

Surf the wave by completing each multiplication problem.

$4 \times 40 =$

$3 \times 8,000 =$

$8 \times 600 =$

$12 \times 50 =$

$5 \times 40,000 =$

$2 \times 500 =$

$2 \times 700 =$

$25 \times 30 =$

$10 \times 3,000 =$

$7 \times 7,000 =$

$12 \times 20 =$

$11 \times 60,000 =$

$6 \times 300 =$

$7 \times 400 =$

$3 \times 20,000 =$

$9 \times 9,000 =$

$7 \times 50 =$

$6 \times 400 =$

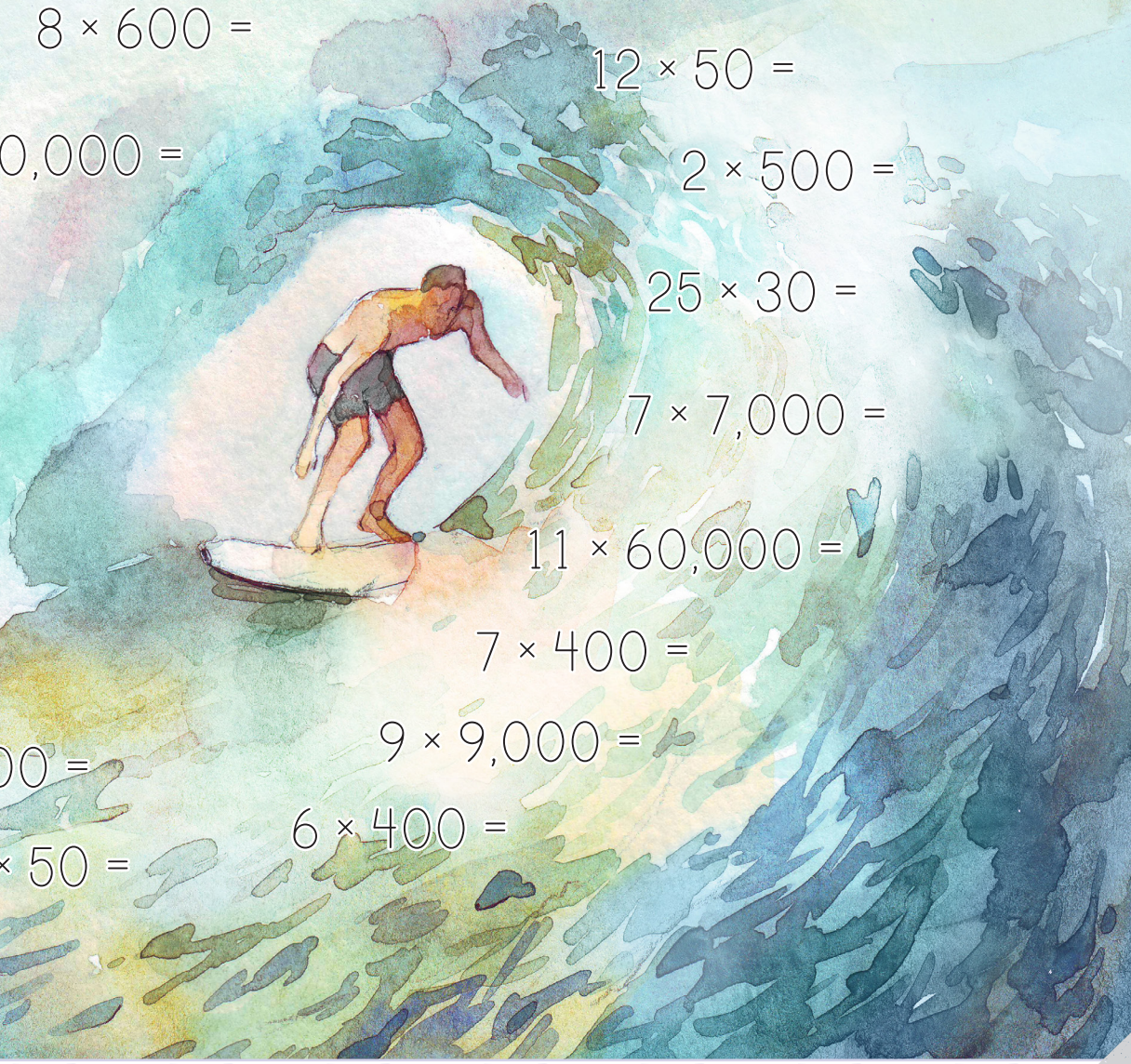

Review

1. Continue each number pattern.

3, 11, 19, 27, 35, _____, _____, _____, _____

1, 2, 4, 8, _____, _____, _____, _____

153, 156, 159, _____, _____, _____, _____

75, 66, 57, 48, _____, _____, _____, _____

2. Complete each problem to find the value of the letter.

$25 + F = 47$ $58 - B = 12$ $36 \div M = 6$

$F = \underline{\quad}$ $B = \underline{\quad}$ $M = \underline{\quad}$

$G + 16 = 39$ $12 \times Z = 72$ $A \times 9 = 54$

$G = \underline{\quad}$ $Z = \underline{\quad}$ $A = \underline{\quad}$

3. Round each number to the nearest thousand.

Hint: Underline the digit in the thousands place and circle the digit to the right.

12,287

3,877

647,515

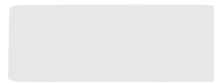
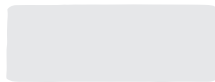
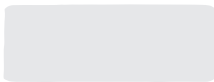

4. Round each number to the nearest ten million.

34,147,362

756,942,025

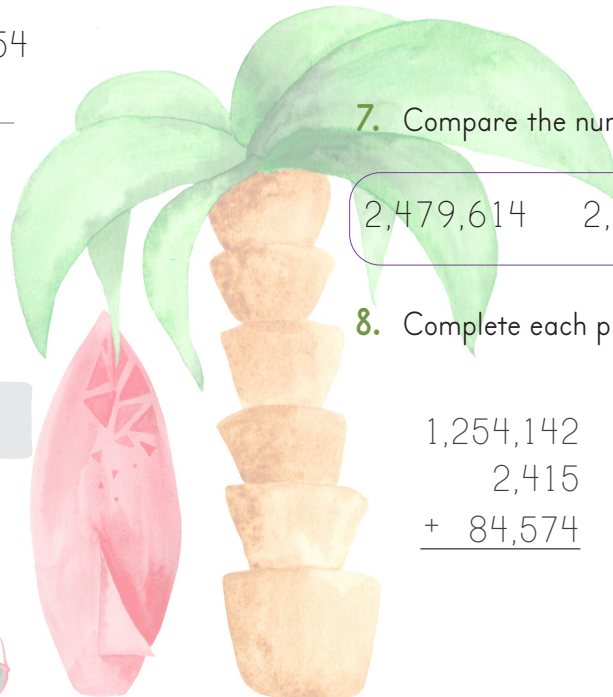
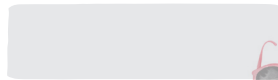
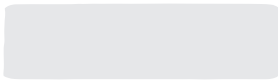

5. Draw a line from each image to the angle type.

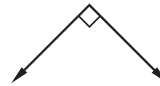
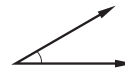
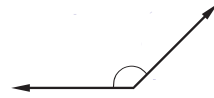

right

acute

obtuse

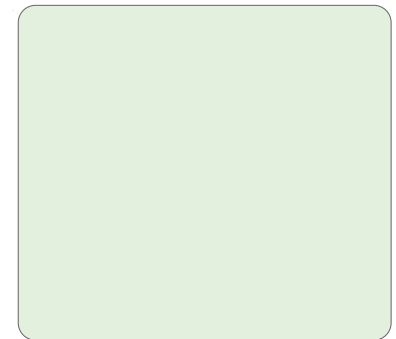

6. Jerry's plane leaves London at 5:42 AM and arrives in Paris at 10:31 AM. How long is the flight?

7. Compare the numbers and write a < or > symbol.

2,479,614 2,479,604

1,240,357 824,752

8. Complete each problem.

1,254,142	517	547,658
2,415	250,475	87,642
+ 84,574	6,344	3,510
_____	+ 7	+ 604



Multiplication *MASTERY*

OPTIONAL: Time yourself to see how long this page takes you to complete. Try to beat your time when you complete the mastery page again, later in this unit.

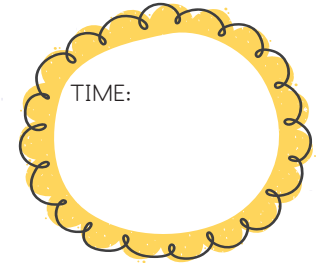

$\begin{array}{r} 11 \\ \times 12 \\ \hline \end{array}$	$\begin{array}{r} 5 \\ \times 4 \\ \hline \end{array}$	$\begin{array}{r} 6 \\ \times 8 \\ \hline \end{array}$	$\begin{array}{r} 12 \\ \times 4 \\ \hline \end{array}$	$\begin{array}{r} 7 \\ \times 8 \\ \hline \end{array}$	$\begin{array}{r} 9 \\ \times 4 \\ \hline \end{array}$	$\begin{array}{r} 6 \\ \times 12 \\ \hline \end{array}$	$\begin{array}{r} 3 \\ \times 8 \\ \hline \end{array}$	$\begin{array}{r} 7 \\ \times 5 \\ \hline \end{array}$	$\begin{array}{r} 12 \\ \times 9 \\ \hline \end{array}$	$\begin{array}{r} 8 \\ \times 9 \\ \hline \end{array}$	$\begin{array}{r} 5 \\ \times 6 \\ \hline \end{array}$	$\begin{array}{r} 7 \\ \times 12 \\ \hline \end{array}$	$\begin{array}{r} 11 \\ \times 4 \\ \hline \end{array}$
--	--	--	---	--	--	---	--	--	---	--	--	---	---

$\begin{array}{r} 7 \\ \times 7 \\ \hline \end{array}$	$\begin{array}{r} 9 \\ \times 12 \\ \hline \end{array}$	$\begin{array}{r} 8 \\ \times 5 \\ \hline \end{array}$	$\begin{array}{r} 6 \\ \times 3 \\ \hline \end{array}$	$\begin{array}{r} 12 \\ \times 3 \\ \hline \end{array}$	$\begin{array}{r} 12 \\ \times 12 \\ \hline \end{array}$	$\begin{array}{r} 4 \\ \times 9 \\ \hline \end{array}$	$\begin{array}{r} 5 \\ \times 5 \\ \hline \end{array}$	$\begin{array}{r} 7 \\ \times 6 \\ \hline \end{array}$	$\begin{array}{r} 4 \\ \times 8 \\ \hline \end{array}$	$\begin{array}{r} 8 \\ \times 12 \\ \hline \end{array}$	$\begin{array}{r} 9 \\ \times 8 \\ \hline \end{array}$	$\begin{array}{r} 12 \\ \times 2 \\ \hline \end{array}$	$\begin{array}{r} 4 \\ \times 4 \\ \hline \end{array}$
--	---	--	--	---	--	--	--	--	--	---	--	---	--

$\begin{array}{r} 5 \\ \times 8 \\ \hline \end{array}$	$\begin{array}{r} 9 \\ \times 5 \\ \hline \end{array}$	$\begin{array}{r} 7 \\ \times 3 \\ \hline \end{array}$	$\begin{array}{r} 12 \\ \times 5 \\ \hline \end{array}$	$\begin{array}{r} 6 \\ \times 7 \\ \hline \end{array}$	$\begin{array}{r} 12 \\ \times 11 \\ \hline \end{array}$	$\begin{array}{r} 9 \\ \times 3 \\ \hline \end{array}$	$\begin{array}{r} 3 \\ \times 6 \\ \hline \end{array}$	$\begin{array}{r} 8 \\ \times 8 \\ \hline \end{array}$	$\begin{array}{r} 5 \\ \times 7 \\ \hline \end{array}$	$\begin{array}{r} 3 \\ \times 12 \\ \hline \end{array}$	$\begin{array}{r} 9 \\ \times 6 \\ \hline \end{array}$	$\begin{array}{r} 3 \\ \times 5 \\ \hline \end{array}$	$\begin{array}{r} 7 \\ \times 9 \\ \hline \end{array}$
--	--	--	---	--	--	--	--	--	--	---	--	--	--

$\begin{array}{r} 5 \\ \times 3 \\ \hline \end{array}$	$\begin{array}{r} 8 \\ \times 4 \\ \hline \end{array}$	$\begin{array}{r} 9 \\ \times 9 \\ \hline \end{array}$	$\begin{array}{r} 12 \\ \times 6 \\ \hline \end{array}$	$\begin{array}{r} 3 \\ \times 4 \\ \hline \end{array}$	$\begin{array}{r} 12 \\ \times 7 \\ \hline \end{array}$	$\begin{array}{r} 6 \\ \times 4 \\ \hline \end{array}$	$\begin{array}{r} 4 \\ \times 5 \\ \hline \end{array}$	$\begin{array}{r} 7 \\ \times 4 \\ \hline \end{array}$	$\begin{array}{r} 12 \\ \times 8 \\ \hline \end{array}$	$\begin{array}{r} 4 \\ \times 3 \\ \hline \end{array}$	$\begin{array}{r} 6 \\ \times 5 \\ \hline \end{array}$	$\begin{array}{r} 9 \\ \times 7 \\ \hline \end{array}$	$\begin{array}{r} 5 \\ \times 12 \\ \hline \end{array}$
--	--	--	---	--	---	--	--	--	---	--	--	--	---

$\begin{array}{r} 3 \\ \times 3 \\ \hline \end{array}$	$\begin{array}{r} 4 \\ \times 6 \\ \hline \end{array}$	$\begin{array}{r} 6 \\ \times 6 \\ \hline \end{array}$	$\begin{array}{r} 4 \\ \times 12 \\ \hline \end{array}$	$\begin{array}{r} 3 \\ \times 7 \\ \hline \end{array}$	$\begin{array}{r} 6 \\ \times 9 \\ \hline \end{array}$	$\begin{array}{r} 4 \\ \times 7 \\ \hline \end{array}$	$\begin{array}{r} 8 \\ \times 6 \\ \hline \end{array}$	$\begin{array}{r} 10 \\ \times 7 \\ \hline \end{array}$	$\begin{array}{r} 5 \\ \times 9 \\ \hline \end{array}$	$\begin{array}{r} 3 \\ \times 0 \\ \hline \end{array}$	$\begin{array}{r} 6 \\ \times 11 \\ \hline \end{array}$	$\begin{array}{r} 2 \\ \times 12 \\ \hline \end{array}$	$\begin{array}{r} 3 \\ \times 9 \\ \hline \end{array}$
--	--	--	---	--	--	--	--	---	--	--	---	---	--

DECIMALS

- Complete today's *Math 4 Mental Math Map Mysteries* activity.
- Watch the video lesson and/or read the mini lesson.

Video Lesson

Scan the QR code or watch the video lesson on goodandbeautiful.com/Math4.

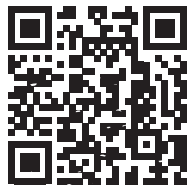

375.29

41.832

3.92

Mini Lesson

The numbers we use every day are part of a number system called the base-10 or decimal system. **Place value** is the value a digit represents based on its place in a number.

Place values to the right of the ones place are less than one. A **decimal number** is a number that has a decimal point. The **decimal point** is a dot that separates a whole number from a fractional part. If there are no fractional parts, a decimal point is not needed.

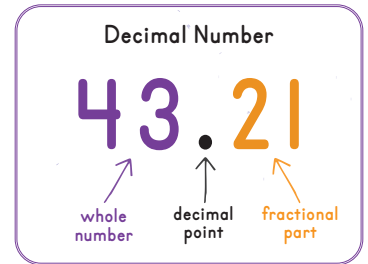

The value of each place is ten times greater than the place to the right and ten times smaller than the place to the left. **Multiply by ten to move one place value to the left.** **Divide by ten to move one place value to the right.** To find the first three place values to the right of the ones, continue to divide by tens.

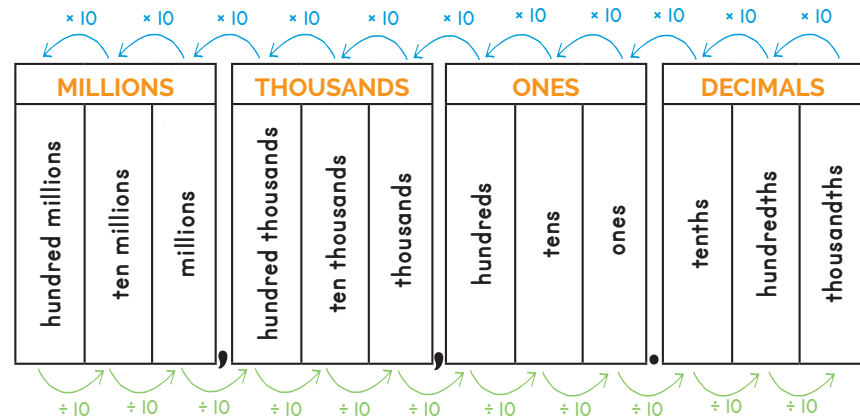

The first three place values to the right of the decimal point are tenths, hundredths, and thousandths.

TENTHS	HUNDREDTHS	THOUSANDTHS
$1 \div 10 = \frac{1}{10} = 0.1$	$\frac{1}{10} \div 10 = \frac{1}{100} = 0.01$	$\frac{1}{100} \div 10 = \frac{1}{1000} = 0.001$

Lesson Practice

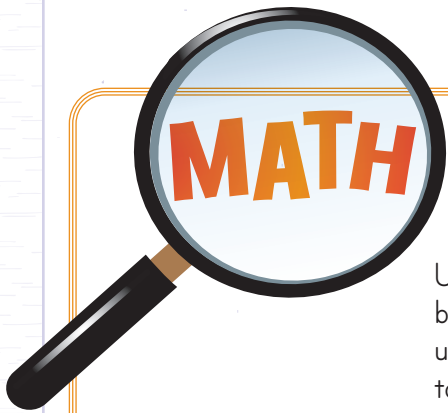

MYSTERIES

Use the clues and the number bank below to fill in the correct answers. Then use the numbers above the colored lines to answer the question at the bottom.

- I have a 3 in the tenths place. .
- I have a 1 in the thousandths place. .
- I have a 3 in the hundredths place. .
- I have an 8 in the tenths place. .
- I have a 1 in the hundredths place. .
- I have an 8 in the thousandths place. .

1.308 61.37 5.841 82.41 71.83 8.334

How many times on average does a hummingbird beat its wings in one minute?

 .



1. Fill in the missing decimal place values.

MILLIONS			THOUSANDS			ONES			DECIMALS		
hundred millions	ten millions	millions	hundred thousands	ten thousands	thousands	hundreds	tens	ones			

2. Follow the instructions to write the number below.

- a) Write a 7 in the hundredths place.
- b) Write a 4 in the ones place.
- c) Write a 3 in the thousandths place.
- d) Write a 5 in the tenths place.
- e) Write a 1 in the tens place.
- f) Write a 2 in the hundreds place.



 .

3. Circle every decimal number that has a 4 in the tenths place.

64.32 9.47 4.841 0.74 673.45 0.489 4.6 0.244

4. Circle every decimal number that has a 7 in the hundredths place.

72.51 7.87 14.247 0.27 123.74 0.574 1.7 0.674

5. Circle every decimal number that has a 2 in the thousandths place.

32.522 7.286 14.247 0.652 123.24 0.542 2.674

Review

1. Shade the shapes to represent each mixed number. Then use the shaded shapes to write the improper fraction.

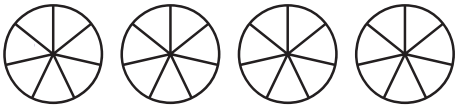
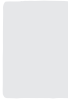
$3 \frac{3}{7}$  

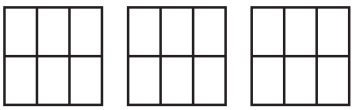
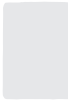
$2 \frac{1}{6}$  

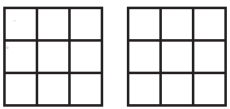
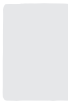
$1 \frac{6}{9}$  

2. Write all the multiples of 12 between 60 and 132.

60, _____, _____, _____, _____, _____, 132

3. Find the volume of each object.

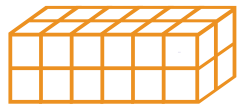
 _____ cubic in

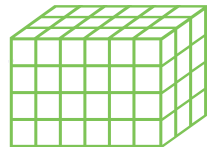
 _____ cubic in

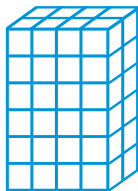
 _____ cubic in

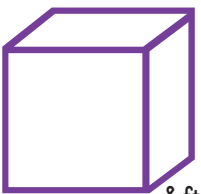
 _____ cubic ft

 _____ cubic in

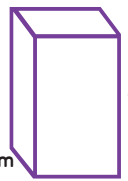
 _____ cubic cm

4. Find the measurement of the missing side. Then find the perimeter and area. *Hint: Divide this shape into three smaller rectangles.*

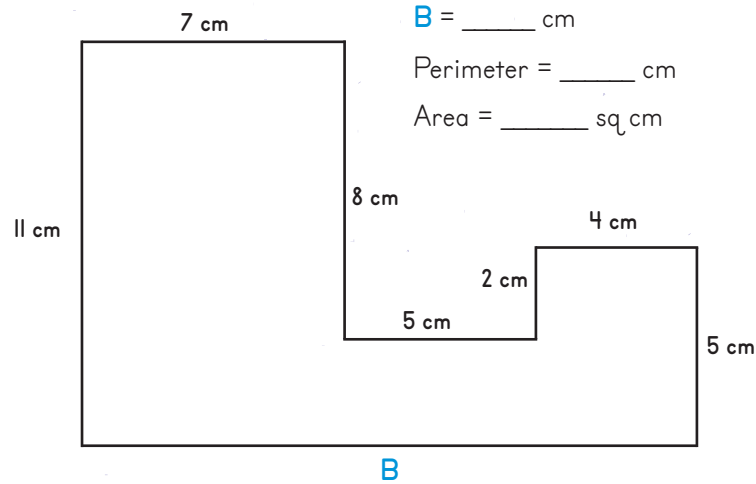

5. Round to the nearest hundred thousand.

3,418,285

12,375,201

6. Circle all the triangles that are congruent to the first triangle.



7. Complete each problem. Use scratch paper if necessary.

$$2 \overline{)1,764}$$

$$9 \overline{)513}$$

$$4 \overline{)296}$$

$$\begin{array}{r} 6 \quad 9 \\ \times 4 \quad \times 5 \\ \hline \end{array}$$

$$\begin{array}{r} 9 \quad 12 \\ \times 8 \quad \times 12 \\ \hline \end{array}$$

$$\begin{array}{r} 3 \quad 5 \\ \times 5 \quad \times 4 \\ \hline \end{array}$$

$$\begin{array}{r} 6 \quad 3 \\ \times 5 \quad \times 12 \\ \hline \end{array}$$

$$\begin{array}{r} 8 \quad 8 \\ \times 8 \quad \times 5 \\ \hline \end{array}$$

$$\begin{array}{r} 7 \quad 12 \\ \times 6 \quad \times 6 \\ \hline \end{array}$$

$$\begin{array}{r} 4 \quad 3 \\ \times 8 \quad \times 7 \\ \hline \end{array}$$

$$\begin{array}{r} 7 \quad 4 \\ \times 5 \quad \times 12 \\ \hline \end{array}$$

Lesson
77

LONG DIVISION: ZERO IN THE QUOTIENT

- Complete today's *Math 4 Mental Math Map Mysteries* activity.
- Watch the video lesson and/or read the mini lesson.

Video Lesson

Scan the QR code or watch the video lesson on goodandbeautiful.com/Math4.

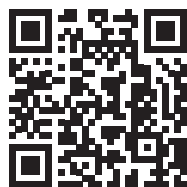

$$3 \overline{)2,709}$$

$$6 \overline{)3,480}$$

Mini Lesson

Sometimes when you are completing a division problem, a digit cannot be divided by the divisor. When this happens, you write "0" in the quotient. The 0 is an important placeholder, and it may be in the middle of a quotient or at the end.

In this example on the right, we have already divided the 6 by 3 and brought down the 1. That 1 cannot be divided

1. Divide ÷
2. Multiply x
3. Subtract -
4. Bring Down ↓

Repeat ↻

evenly by 3, so a 0 is written as the second digit of the quotient. It is an important placeholder because it tells us exactly how many tens are in our quotient: 0! We then continue through the long division steps to complete the problem.

$$\begin{array}{r} 20 \\ 3 \overline{)618} \\ \underline{-6} \\ 01 \end{array}$$

$$\begin{array}{r} 206 \\ 3 \overline{)618} \\ \underline{-6} \\ 01 \\ \underline{-0} \\ 18 \\ \underline{-18} \\ 0 \end{array}$$

We can check the answer by multiplying the quotient by the divisor: $206 \times 3 = 618$. It's the same as the dividend, so our answer is correct!

Remember, 0 is an important placeholder. Without the 0, the quotient would have been 26. We can see this quotient would be incorrect because when we check the answer we get $26 \times 3 = 78$.

Check the answer

$$\begin{array}{r} 206 \\ \times 3 \\ \hline 618 \end{array}$$

$$\begin{array}{r} 210 \\ 4 \overline{)840} \\ \underline{-8} \\ 04 \\ \underline{-4} \\ 00 \\ \underline{-0} \\ 0 \end{array}$$

Here is an example where the 0 is needed at the end of the quotient. Every digit in a dividend must be divided by the divisor or brought down. Zero ones divided into four groups is 0 in each group. So a 0 is written as the last digit in the quotient. We can check the answer using multiplication!

Check the answer

$$\begin{array}{r} 210 \\ \times 4 \\ \hline 840 \end{array}$$

Lesson Practice

Complete each problem using long division on scratch paper.

1. Daisy drove 240 miles in 3 hours. If she drove the same number of miles each hour, how many miles did she drive each hour?
2. Marco is trying to fit 618 books equally on 3 bookshelves. How many books will he put on each shelf?
3. Chelsea flew 2,730 miles in 7 hours. If she flew the same number of miles each hour, how many miles did she fly each hour?
4. Michelle makes the same amount of money each week at her job. After 5 weeks of dog walking, she earned \$530. How much did she make each week?

1.	Divide	\div
2.	Multiply	\times
3.	Subtract	$-$
4.	Bring Down	\downarrow

Repeat \curvearrowright



5. Darius and Jamal caught 120 trout at the fishing hole. How many fish will each boy get if they split them equally?
6. Isabella works at a local pizza restaurant. She made 612 pizzas in the last 6 days. If she made the same number of pizzas each day, how many pizzas did she make each day?
7. Kim and Juan are baking cookies for a fundraiser. They baked 428 cookies and packaged them in groups of 4. How many cookie packages do they have?
8. Gerald volunteered for 50 hours over the last 5 days. If he volunteered the same number of hours daily, how many hours did he volunteer each day?
9. Kojo is helping to build a school for boys and girls who live in the African village of Nzuri. There are 320 students who will be divided evenly into 8 classrooms. How many students will be learning in each classroom?

DOT • TO • DOT REVIEW



Complete each problem below. Then use the answers to complete the dot-to-dot picture on the next page. Start at the red number 1. Draw a line to the answer to Problem 2, and then draw a line to the answer to Problem 3. The numbers in red have been done for you; simply find that number on the dot-to-dot.

1. 1	2. $400 \times 20 =$	3. $12 \times 300 =$	4. $60 \times 50 =$	5. 5
6. IV -	7. XXVII -	8. CX -	9. LI -	10. 10
11. $2 \overline{)254}$	12. $4 \overline{)735}$	13. $5 \overline{)355}$	14. $8 \overline{)169}$	15. 15
16. $6 \times 4 =$	17. $8 \times 7 =$	18. $6 \times 9 =$	19. $5 \times 12 =$	20. 20
21. $\frac{1}{3} + \frac{4}{21} = \underline{\quad}$	22. $\frac{7}{8} - \frac{1}{2} = \underline{\quad}$	23. $\frac{9}{20} + \frac{1}{5} = \underline{\quad}$	24. $\frac{4}{6} - \frac{7}{24} = \underline{\quad}$	25. 25
26. $31.745 - 9.6 =$	27. $4.57 - 0.004 =$	28. $61.9 - 4.78 =$	29. $8.32 - 1.5 =$	30. 30
31. $3 \times 7 =$	32. $9 \times 7 =$	33. $12 \times 4 =$	34. $6 \times 6 =$	35. 35
36. 34 yd = <u> </u> ft	37. 6 ft = <u> </u> in	38. 30 mm = <u> </u> cm	39. 600 cm = <u> </u> m	40. 40
41. $23 \times 14 =$	42. $45 \times 19 =$	43. 27, 23, 19, 15, <u> </u>	44. 7, 14, 21, <u> </u>	45. 45
46. Radius = 13 cm Diameter = <u> </u> cm	47. Radius = 32 ft Diameter = <u> </u> ft	48. Radius = <u> </u> in Diameter = 140 in	49. Radius = <u> </u> m Diameter = 84 m	50. 50















UNIT 4 OVERVIEW

LESSONS 91-120





Extra Supplies Needed

-  2 standard dice
-  1 quarter
-  colored pencils or crayons

New Concepts Taught

-  add/subtract mixed numbers (uncommon denominators)
-  compare decimal numbers to the thousandths place
-  estimation (multiplication and division)
-  long division (check quotients using multiplication)
-  long division (decimal numbers)
-  long division (two-digit divisor)
-  mean, median, mode, and range
-  mental math (multiplication)
-  multiplication (decimal numbers)
-  multiplication (three-digit by two-digit)
-  percents
-  round decimal numbers to the ones and tenths place
-  short division
-  write fractions and mixed numbers as decimals

Concepts Reviewed and Expanded Upon

-  compare positive and negative numbers
-  conversion (units of weight)
-  coordinate graph
-  fractions of a set
-  identify positive and negative numbers

Parent/Teacher Tips

Students are not expected to completely master all the concepts taught in Unit 4, especially toward the end of the unit. Some concepts are presented to give the student familiarity with topics that will be taught and expanded on in Math 5.

ADDING AND SUBTRACTING MIXED NUMBERS

📖 Complete today's *Math 4 Mental Math Map Mysteries* activity.

📺 Watch the video lesson and/or read the mini lesson.

Video Lesson

Scan the QR code or watch the video lesson on goodandbeautiful.com/Math4.

$$4 \frac{3}{8} + 2 \frac{1}{8} =$$

$$3 \frac{4}{5} - 2 \frac{2}{5} =$$

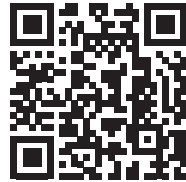

$$7 \frac{2}{3} + 2 \frac{1}{9} =$$

$$6 \frac{4}{5} - 3 \frac{3}{10} =$$

Mini Lesson

Adding and subtracting mixed numbers is similar to adding and subtracting fractions. In these two problems, the fractions have common denominators. For the addition problem, add the **whole numbers**, and then add the **fractions**. For the subtraction problem, subtract the **whole numbers**, and then subtract the **fractions**.

Add Whole Numbers $3 + 2 = 5$

$$3 \frac{1}{10} + 2 \frac{2}{10} = 5 \frac{3}{10}$$

Add Fractions $\frac{1}{10} + \frac{2}{10} = \frac{3}{10}$

Subtract Whole Numbers $4 - 2 = 2$

$$4 \frac{6}{7} - 2 \frac{3}{7} = 2 \frac{3}{7}$$

Subtract Fractions $\frac{6}{7} - \frac{3}{7} = \frac{3}{7}$

Sometimes the fraction parts will not have a common denominator. Before any addition or subtraction can take place, the fraction parts of the mixed numbers must have a common denominator. Once a common denominator is found, the mixed numbers can be added or subtracted by first adding or subtracting the whole numbers and then adding or subtracting the fractions.

$$2 \frac{3}{8} + 1 \frac{1}{2} =$$

In this problem the fractions do not have a common denominator. We must find a common denominator before adding.

$$\frac{1}{2} \xrightarrow{\times 4} \frac{4}{8}$$

We find an equivalent fraction for one-half with a denominator of eight and replace one-half with four-eighths.

Add Whole Numbers $2 + 1 = 3$

$$2 \frac{3}{8} + 1 \frac{4}{8} = 3 \frac{7}{8}$$

Add Fractions $\frac{3}{8} + \frac{4}{8} = \frac{7}{8}$

$$5 \frac{7}{9} - 2 \frac{1}{3} =$$

In this problem the fractions do not have a common denominator. We must find a common denominator before subtracting.

$$\frac{1}{3} \xrightarrow{\times 3} \frac{3}{9}$$

We find an equivalent fraction for one-third with a denominator of nine and replace one-third with three-ninths.

Subtract Whole Numbers $5 - 2 = 3$

$$5 \frac{7}{9} - 2 \frac{3}{9} = 3 \frac{4}{9}$$

Subtract Fractions $\frac{7}{9} - \frac{3}{9} = \frac{4}{9}$



$$9\frac{1}{3} - 2\frac{1}{6}$$

$$4\frac{9}{10} - 2\frac{1}{5}$$

$$8\frac{10}{12} - 2\frac{4}{6}$$

$$2\frac{1}{9} + 2\frac{2}{3}$$

$$1\frac{1}{2} + 1\frac{1}{10}$$

$$1\frac{1}{4} + 5\frac{4}{12}$$

$$5\frac{2}{3} - 1\frac{2}{9}$$

$$3\frac{2}{6} + 4\frac{1}{2}$$

$$7\frac{5}{6}$$

$$4\frac{7}{9}$$

$$2\frac{6}{10}$$

$$7\frac{1}{6}$$

$$2\frac{7}{10}$$

$$4\frac{4}{9}$$

$$6\frac{2}{12}$$

$$6\frac{7}{12}$$

Help each bird get back to its birdhouse by completing each problem and then drawing a line from the bird to the birdhouse with the correct answer.

Instructions

1. Attach back piece to left side. Make sure the left side's top slants down away from back piece.

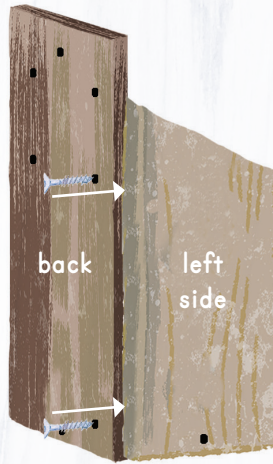

2. Attach right side to back. Drill screw into hole so it is not snug. This screw will act as a hinge.

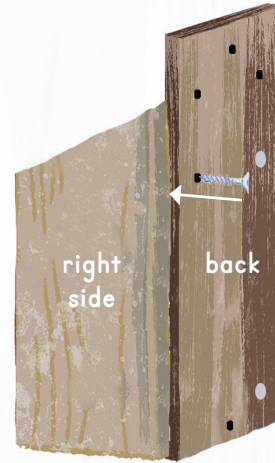

3. Slide floor piece in position. Drill screws into back and left side.

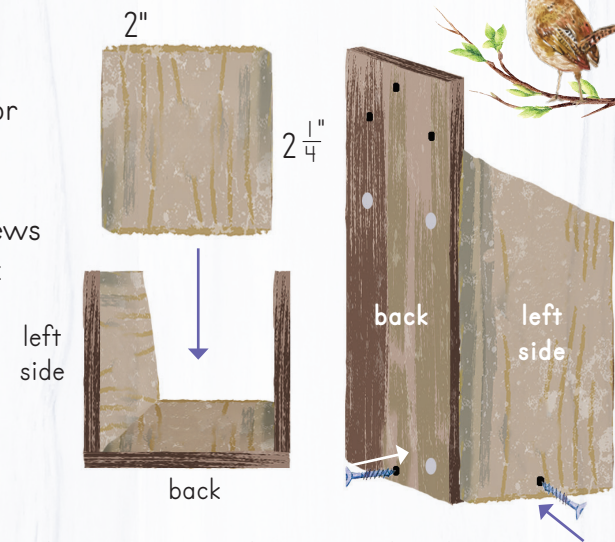

4. Attach front to left side and floor. Drill screw into top hole only for right side, making sure it is not snug. This screw will act as another hinge.

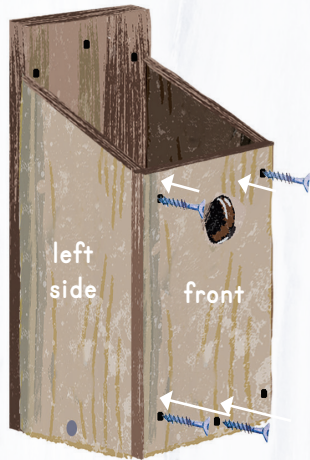

5. Attach roof to front, and then to back. There will be a $\frac{1}{4}$ " gap between roof and top of sides to allow for airflow.

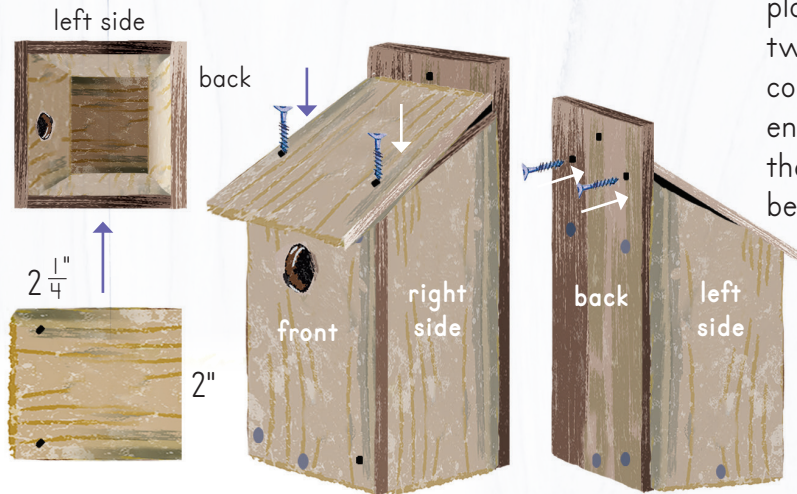

6. Use pliers to screw the square bend screw hook clockwise into bottom right hole on front piece. This will lock the right side in place. To unlock, twist screw counterclockwise enough so that the right side can be opened.

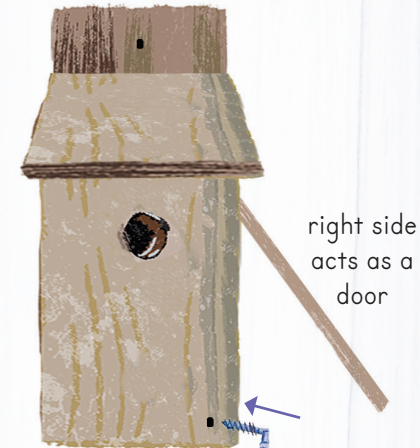

7. Attach birdhouse to tree, post, or fence. In early winter, ease the side door open to clean out old nests. Make sure there are no birds still living in the nest before removing it.



LONG DIVISION: DIVIDING BY 10

- Complete today's *Math 4 Mental Math Map Mysteries* activity.
- Watch the video lesson and/or read the mini lesson.

Video Lesson

Scan the QR code or watch the video lesson on goodandbeautiful.com/Math4.

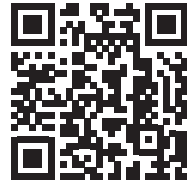

$$10 \overline{)5,480}$$

$$10 \overline{)2,497}$$

Mini Lesson

1. Divide \div
 2. Multiply \times
 3. Subtract $-$
 4. Bring Down \downarrow
- Repeat

Dividing by 10 is a type of math problem that can be completed by using long division. Remember, the four steps of long division are repeated until there are no more digits to bring down.

$$\begin{array}{r} 52 \\ 10 \overline{)520} \\ \underline{-50} \downarrow \\ 20 \\ \underline{-20} \\ 0 \end{array}$$

$$\begin{array}{r} 374 \\ 10 \overline{)3,740} \\ \underline{-30} \downarrow \downarrow \\ 74 \\ \underline{-70} \downarrow \downarrow \\ 40 \\ \underline{-40} \\ 0 \end{array}$$

If we divide 520 into 10 equal groups, there will be 52 in each group and no remainder. If we divide 3,740 into 10 equal groups, there will be 374 in each group and no remainder.

In both of these problems, the dividends end in a 0, and there is no remainder in the quotient. When dividing 10 into a number that ends with 0, there is no remainder.

If we divide 6,896 into 10 equal groups, there will be 689 in each group with 6 left over. The quotient for this problem is 689 R6.

$$\begin{array}{r} 689 \text{ R}6 \\ 10 \overline{)6,896} \\ \underline{-60} \downarrow \downarrow \\ 89 \\ \underline{-80} \downarrow \downarrow \\ 96 \\ \underline{-90} \\ 6 \end{array}$$



Hot Dogs



Complete each division problem as you learn about hot dogs around the world.

In Germany hot dogs are eaten with sauerkraut, mustard, potato salad, and no bun!

$$10 \overline{) 3,521}$$

$$10 \overline{) 360}$$

AROUND THE WORLD

In Peru hot dogs are sliced and served over fries with ketchup, mayo, and mustard.

$$10 \overline{) 6,250}$$

In China hot dogs are wrapped in a dumpling and baked.

$$10 \overline{) 810}$$

In France the hot dog comes in a baguette with Gruyère cheese.

In Sweden hot dogs are wrapped up with mashed potatoes, shrimp salad, and fried onions.

$$10 \overline{) 1,540}$$

$$10 \overline{) 477}$$

In Japan the hot dog is cut to look like a little octopus and then deep-fried!

$$10 \overline{) 768}$$

$$10 \overline{) 2,570}$$

$$10 \overline{) 457}$$

In the Philippines hot dogs are served with banana ketchup, rice, and a fried egg.

$$10 \overline{) 4,237}$$

In Vietnam hot dogs are served in a roll called banh mi with pickled vegetables on top.



FRACTIONS, MIXED NUMBERS, AND DECIMALS

- Complete today's *Math 4 Mental Math Map Mysteries* activity.
- Watch the video lesson and/or read the mini lesson.

Video Lesson

Scan the QR code or watch the video lesson on goodandbeautiful.com/Math4.

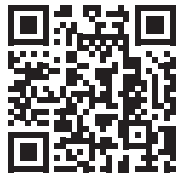

$$12\frac{1}{2} =$$

$$34\frac{3}{4} =$$



Mini Lesson

Here is a group of four dots; $\frac{1}{4}$ of this group is 1 of the dots.



We can use money to help us learn some common fraction and decimal equivalents. A dollar can be broken down into a group of four quarters.

Remember, a quarter is \$0.25, and a quarter is $\frac{1}{4}$ of a dollar.



Three quarters is \$0.75, and three quarters is $\frac{3}{4}$ of a dollar.



A dollar can also be broken into a group of two half-dollars. One half-dollar is $\frac{1}{2}$ of a dollar, which is \$0.50.



Recall that zeros can be placed at the end of a decimal number without changing its value: $0.5 = 0.50$. Amounts of money are usually written to the hundredths place, even if there are zeros in the tenths or hundredths places.

To write the mixed number $3\frac{1}{2}$ as a decimal number, the whole number remains the same, and the fraction is written as a decimal. Since $\frac{1}{2} = 0.5$, the decimal number is 3.5.

$$3\frac{1}{2} = 3.5$$

$$6\frac{3}{4} = 6.75$$

To write the mixed number $6\frac{3}{4}$ as a decimal number, the whole number remains the same, and the fraction is written as a decimal. Since $\frac{3}{4} = 0.75$, the decimal number is 6.75.

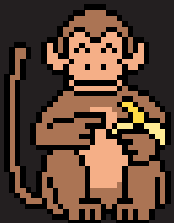

MEGA MONKEY MATH PATH

Lesson Practice

Simplify each mixed number, and then convert it to a decimal number. Write your answers in the white boxes. The first has been done for you. Then find your answers in order to help the monkey navigate the maze. Use a white crayon to trace your path.

$3 \frac{3}{12}$

$4 \frac{2}{4}$

1. $3 \frac{1}{4}$ 3.25

2.

$1 \frac{12}{16}$

$2 \frac{2}{8}$

3.

4.

$6 \frac{5}{10}$

$5 \frac{6}{8}$

5.

6.

$1 \frac{5}{20}$

$1 \frac{4}{8}$

7.

8.

$3 \frac{3}{6}$

$2 \frac{15}{20}$

9.

10.

$4 \frac{4}{16}$

$3 \frac{9}{12}$

11.

12.

GAME LESSON: COORDINATE PLANES

📖 Complete today's *Math 4 Mental Math Map Mysteries* activity.

📺 There is no video or review for this lesson.

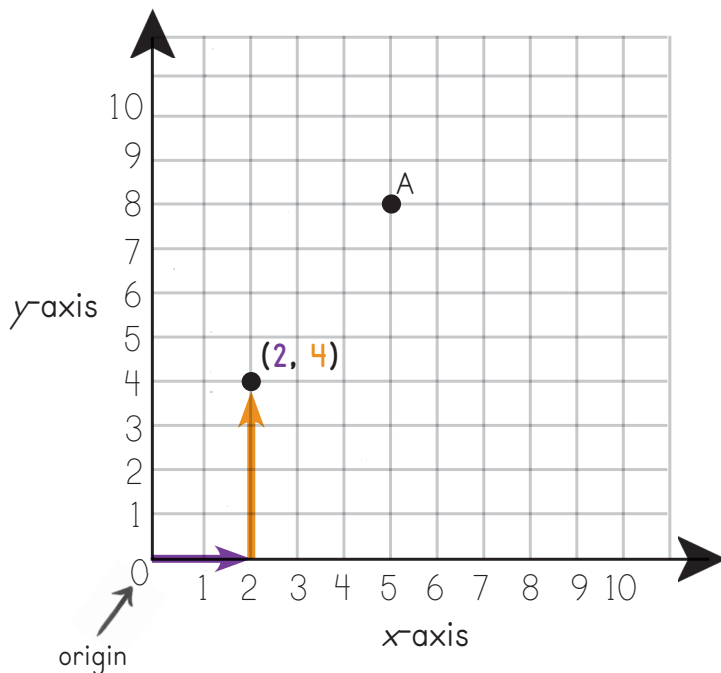

Mini Lesson

A **coordinate plane** is a two-dimensional plane formed by the intersection of a horizontal **x-axis** and a vertical **y-axis**. The **x-axis** is the horizontal number line on a coordinate plane, and the **y-axis** is the vertical number line on a coordinate plane. The **origin** is the point where the x-axis and the y-axis intersect.

An **ordered pair** is a pair of numbers used to show the location of a point on a coordinate plane.

An example of an ordered pair (2, 4) can be seen on the coordinate plane.

The location of a point is written as two numbers inside parentheses with a comma between them.

The first number, called the **x-coordinate**, gives the horizontal position. It shows how far to the right to move along the x-axis, starting at the origin.

The second number, called the **y-coordinate**, gives the vertical position. It shows how far up to move along the y-axis, starting at the x-axis.

To find the ordered pair for Point A, follow these steps:

Look along the x-axis to see how far to the right Point A is from the origin. It is 5 units to the right. This number, 5, is the x-coordinate.

Look along the y-axis to see how far up Point A is from the x-axis. It is 8 units up. This number, 8, is the y-coordinate.

Write the x-coordinate first and the y-coordinate second inside parentheses. Separate the coordinates with a comma. Point A is located at (5, 8) on the coordinate plane.

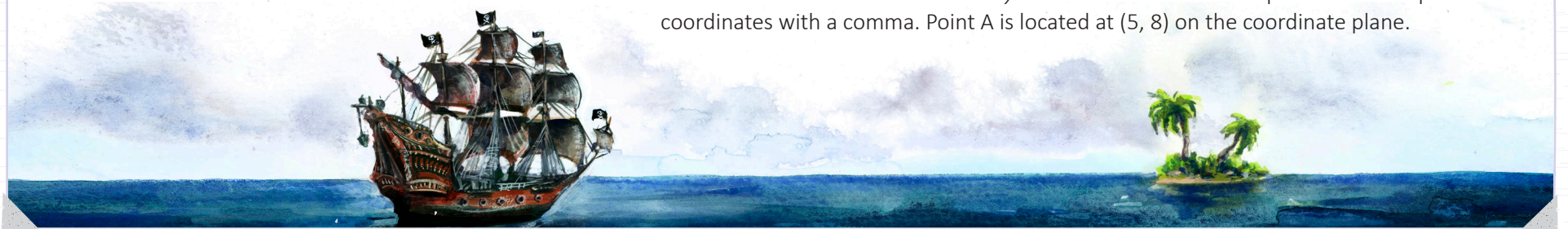



TREASURE HUNT

Are you ready to go on a treasure hunt? Use the ordered pairs listed to find the path to the treasure chest. As you find each point, write the letter for that ordered pair in the box at the bottom of the next page. Connect the points in order as you travel across the map.



- Path to the Treasure
- (5, 1)
 - ↓
 - (6, 3)
 - ↓
 - (4, 3)
 - ↓
 - (3, 4)
 - ↓
 - (2, 6)
 - ↓
 - (5, 7)
 - ↓
 - (7, 7)
 - ↓
 - (7, 5)
 - ↓
 - (8, 3)
 - ↓
 - (9, 2)



JEWELS of Logic

You found the treasure! The treasure chest is full of beautiful jewels. For each multiplication and division problem, find the missing number represented by the jewel, and write that number next to the jewel. Once you have found the number for a jewel, use that same number in the next problem working from top to bottom, and then up to the next column. Once it is completed, you will have solved for all the missing jewels, and you will find the last pieces to the puzzle in the box below.

$20 \div 5 = \text{jewel}$

$\text{jewel} \times \text{jewel} = 35$

$\text{jewel} \times \text{jewel} = 9$

$\text{jewel} \times \text{jewel} = 24$

$70 \div \text{jewel} = \text{jewel}$

$\text{jewel} \div \text{jewel} = \text{jewel}$

$30 \div \text{jewel} = \text{jewel}$

$\text{jewel} \times \text{jewel} = 90$

$\text{jewel} \div \text{jewel} = \text{jewel}$

Find this verse in your Bible and write it down on the lines provided.

(5,1) (6,3) (4,3) (3,4) (2,6) (5,7) (7,7) (7,5) (8,3) (9,2)





REVIEW GAME: UNITS 3 AND 4

📖 Complete today's *Math 4 Mental Math Map Mysteries* activity.

Are you ready to continue exploring the country of Italy? Let's get started. Remember to follow the itinerary below and to complete each of the problems in that specific city box before moving on to the next city.

DAY 6

You leave Pisa and head for Florence. You start driving at 9:05 AM and drive for 1 hour and 22 minutes. What time do you arrive?

You're only passing through Florence, but you drive by the Florence Cathedral with its amazing terracotta-tiled dome.

Three hours later you arrive in Rome, the capital of Italy. You're excited to see the ruins of Ancient Rome, like the Pantheon and Colosseum.

DAY 7

Today's itinerary takes you to the archaeological site of Pompeii to stand in the shade of Mount Vesuvius, the famous volcano that covered the thriving town with ashes in 79 AD.



Find the area of each triangle.

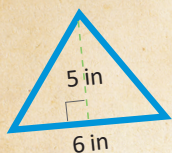

8 in



11 in

sq in

sq in

Find the perimeter and area of the shape below.



12 in

7 in

Perimeter =

Area =

Find the volume of each solid.

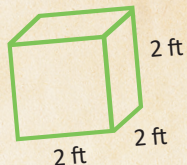

2 ft 2 ft

cubic ft

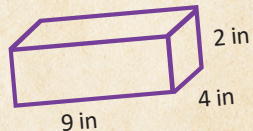

9 in

4 in

cubic in

AIR MAIL 2



Visit Picturesque **POMPEII**



ROAMING IN ROME, ITALY

Continue the pattern.

-20, -15, -10, , ,

List THREE factor pairs of 12.

List FIVE multiples of 8, starting at 24.

Convert from factored form to exponent form.

$$2 \times 2 \times 2 \times 2 =$$

$$3 \times 3 \times 3 \times 3 \times 3 =$$

$$7 \times 7 \times 7 \times 7 \times 7 \times 7 \times 7 =$$

$$5 \times 5 \times 5 =$$

$$4 \times 4 =$$



AIR MAIL 4



Add or subtract the mixed numbers, and then write the answers in simplest form in the gray boxes.

$$5 \frac{11}{12} - 2 \frac{1}{6} =$$

$$3 \frac{1}{2} + 2 \frac{2}{8} =$$

Use the box to divide the number 8 into 4 equal groups and answer the question.



What is $\frac{3}{4}$ of 8?

Convert each improper fraction to a mixed number.

$$\frac{11}{4}$$

$$\frac{13}{8}$$

FLORENCE, ITALY



AIR MAIL 5

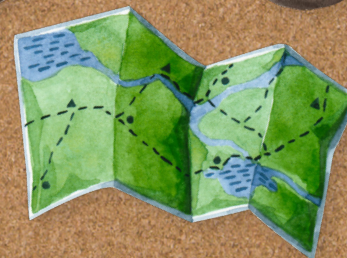



12.4.10
 FT ERS CASPI T.
 P. 54004

AIR MAIL 10

Salutations from Sardinia

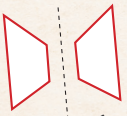
Label each geometric transformation.





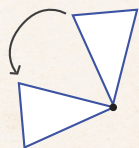

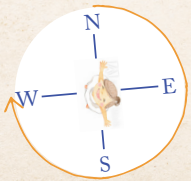

Write the measurement in degrees of each clockwise turn.

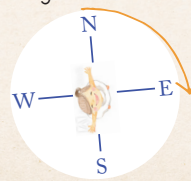

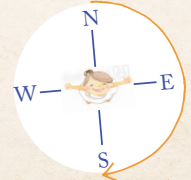

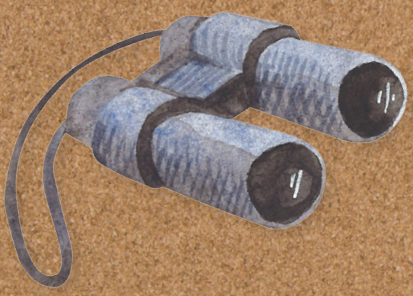

SEEING SIGHTS IN SICILY, ITALY

Circle all the prime numbers.

3	12	25	11
8	62	2	
13	4	48	9
80	17	5	

Write each perfect square.

$6^2 =$ _____ $8^2 =$ _____
 $5^2 =$ _____ $3^2 =$ _____



Complete each problem using the order of operations.
 Use scratch paper if you need more room.



$3^2 + (12 \div 4) =$ _____

$2 \times (15 - 6) + 4 =$ _____

AIR MAIL 8



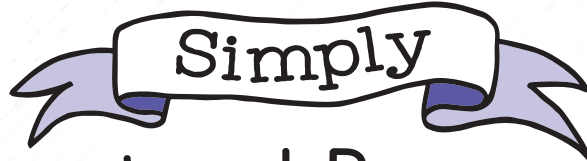

Good and Beautiful

MATH 4

ANSWER

KEY

Hexagonal Honeycombs

Starting at the circled 3, use skip counting by 3s to color in every third hexagon on the first honeycomb.

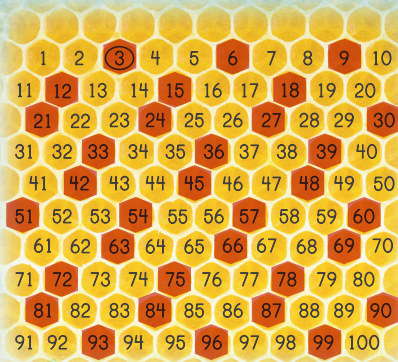

On the second honeycomb, start at the circled 6 and use skip counting by 6s to color in every sixth hexagon.

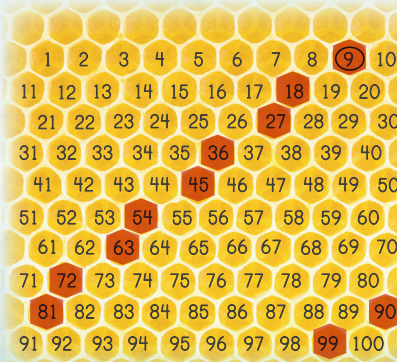
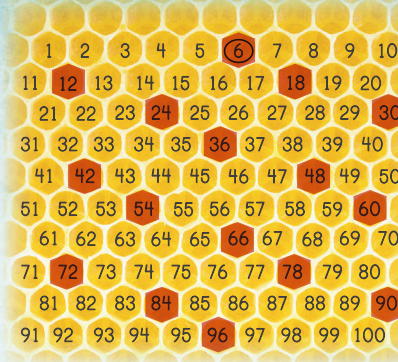

Starting at the circled 9, use skip counting by 9s to color in every ninth hexagon on the third honeycomb.

Look at the numbers you colored in the last honeycomb. Which number pattern do they follow?

EVEN, EVEN, EVEN, EVEN
EVEN, ODD, EVEN, ODD

Lesson Practice

1. Write a sequence by skip counting by 7s.

7, 14, 21, 28, 35, 42, 49, 56, 63

2. Circle the correct pattern for the sequence above.

EVEN, EVEN, EVEN, EVEN **EVEN, ODD, EVEN, ODD**

3. Fill in the missing numbers for the following sequence:

8, 16, 24, 32, 40, 48,
56, 64, 72, 80, 88

4. Write the minutes around the outside of the clock by skip counting by 5s. The first two have been done for you.



5. Circle the numbers on the number lines that follow the pattern of skip counting by 4s.

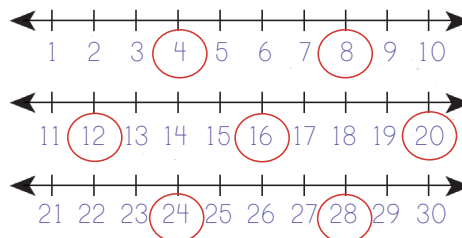

Review

1. Continue adding triangles to complete the pattern.

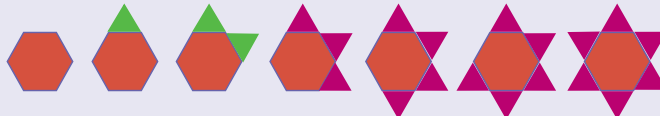

2. Is this pattern a growing pattern or a repeating pattern? growing

3. Complete the multiplication problems.

$$\begin{array}{r} 1 \\ \times 9 \\ \hline 9 \end{array} \quad \begin{array}{r} 3 \\ \times 1 \\ \hline 3 \end{array} \quad \begin{array}{r} 8 \\ \times 1 \\ \hline 8 \end{array} \quad \begin{array}{r} 1 \\ \times 1 \\ \hline 1 \end{array} \quad \begin{array}{r} 5 \\ \times 1 \\ \hline 5 \end{array} \quad \begin{array}{r} 1 \\ \times 7 \\ \hline 7 \end{array} \quad \begin{array}{r} 1 \\ \times 0 \\ \hline 0 \end{array} \quad \begin{array}{r} 2 \\ \times 1 \\ \hline 2 \end{array}$$

Let's finish our addition review by adding dollars and cents. Look at this problem:

$$\begin{array}{r} \$15.32 \\ + \$7.64 \\ \hline \end{array}$$

When adding money, always line up the decimal points and include the dollar signs. You can then add, starting on the right.

$$\begin{array}{r} 1 \\ \$15.32 \\ + \$7.64 \\ \hline 22.96 \end{array}$$

Don't forget! When adding money, you need to write a decimal point and a dollar or a cent sign in the answer.

$$\begin{array}{r} 1 \\ \$15.32 \\ + \$7.64 \\ \hline \$22.96 \end{array}$$

Do you still have questions after reading the mini lesson? Watch (or rewatch) the video!

Lesson Practice

1. Circle the addends in each problem, and then find the sum.

$\begin{array}{r} 22 \\ + 13 \\ \hline 35 \end{array}$	$\begin{array}{r} 234 \\ + 61 \\ \hline 295 \end{array}$	$\begin{array}{r} 124 \\ + 40 \\ \hline 164 \end{array}$
--	--	--

2. Use the commutative property to rewrite this equation by changing the order of the addends.

$$\begin{array}{l} 23 + 15 = 38 \\ 15 + 23 = 38 \end{array}$$

3. Complete the problems.

$\begin{array}{r} 351 \\ + 178 \\ \hline 529 \end{array}$	$\begin{array}{r} 34 \\ + 29 \\ \hline 63 \end{array}$	$\begin{array}{r} \$49.42 \\ + \$6.37 \\ \hline \$55.79 \end{array}$	$\begin{array}{r} 126 \\ + 103 \\ \hline 229 \end{array}$	$\begin{array}{r} \$24.61 \\ + \$8.63 \\ \hline \$33.24 \end{array}$
---	--	--	---	--



Review

1. On the centimeter side, skip count by 3s and circle the numbers. On the inch side, skip count by 2s and circle the numbers.

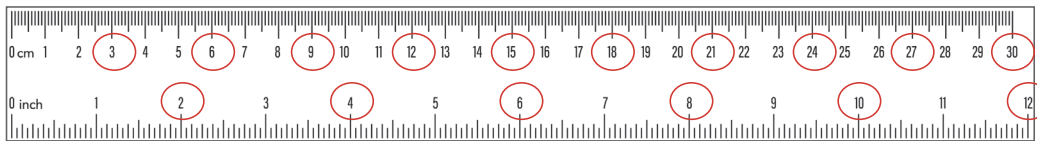

2. You and your best friend are each baking cupcakes to sell together this weekend at the farmers market. You baked 36 strawberry cream cupcakes, and your best friend baked 48 double chocolate cupcakes. How many cupcakes will you have altogether to sell this weekend? Show your work in the box to the right.

$$\begin{array}{r} 36 \\ + 48 \\ \hline 84 \text{ cupcakes} \end{array}$$

3. You plan to sell each cupcake for \$4. Continue this skip counting number pattern to determine how much money you will have after selling 13 cupcakes.

\$4, \$8, \$12, \$16, \$20, \$24, \$28, \$32, \$36, \$40, \$44, \$48, \$52

4. On Saturday you and your friend added up all the money you made. After paying your moms back for groceries to make the cupcakes, you had \$47.24 and your friend had \$54.47. How much money did you and your friend make together?

$$\begin{array}{r} \$47.24 \\ + \$54.47 \\ \hline \$101.71 \end{array}$$



5. Label the hours on the clock from 1 to 12, and then draw the hour and minute hands to show 9:15.



6. Circle the even numbers and cross out the odd.

~~384~~, ~~8,471~~, ~~222~~, 6, ~~50~~
20,484, ~~17~~, ~~5,077~~, 528, ~~4,179~~

7. Complete the multiplication problems.

$\begin{array}{r} 2 \\ \times 9 \\ \hline 18 \end{array}$	$\begin{array}{r} 4 \\ \times 2 \\ \hline 8 \end{array}$	$\begin{array}{r} 6 \\ \times 2 \\ \hline 12 \end{array}$	$\begin{array}{r} 2 \\ \times 3 \\ \hline 6 \end{array}$
$\begin{array}{r} 2 \\ \times 5 \\ \hline 10 \end{array}$	$\begin{array}{r} 8 \\ \times 2 \\ \hline 16 \end{array}$	$\begin{array}{r} 2 \\ \times 2 \\ \hline 4 \end{array}$	$\begin{array}{r} 2 \\ \times 0 \\ \hline 0 \end{array}$

BUILDING BRIDGES

Answers will vary. An example is given for each triangle.

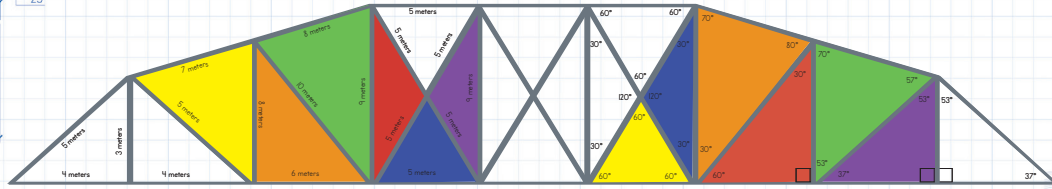

This bridge has many different types of triangles. The triangles on the left side of the bridge show side lengths. The triangles on the right side of the bridge show angle measures. Find each type of triangle described below and, using colored pencils, color one triangle on the bridge for each description. NOTE: Triangles may not be drawn to scale.

By Side

This **SCALENE** triangle has two sides that measure 10 meters and 9 meters. Color this triangle **GREEN**.

This **ISOSCELES** triangle has two sides that measure 5 meters. Color this triangle **RED**.

This **ACUTE** triangle has an angle that measures 57° and an angle that measures 70°. Color this triangle **GREEN**.

This **RIGHT** triangle has an angle that measures 30° and an angle that measures 60°. Color this triangle **RED**.

This **EQUILATERAL** triangle has equal sides that measure 5 meters. Color this triangle **BLUE**.

This **SCALENE** triangle has two sides that measure 7 meters and 8 meters. Color this triangle **YELLOW**.

This **OBTUSE** triangle has an angle that measures 120°. Color this triangle **BLUE**.

This **ACUTE** triangle has three angles that measure 60°. Color this triangle **YELLOW**.

This **SCALENE** triangle has two sides that measure 6 meters and 8 meters. Color this triangle **ORANGE**.

This **ISOSCELES** triangle has two sides that measure 5 meters. Color this triangle **PURPLE**.

This **ACUTE** triangle has an angle that measures 80° and an angle that measures 30°. Color this triangle **ORANGE**.

This **RIGHT** triangle has an angle that measures 53° and an angle that measures 37°. Color this triangle **PURPLE**.

1. Divide ÷
2. Multiply ×
3. Subtract -
4. Bring Down ↓

1. Complete the problems.

$$\begin{array}{r} 61 \\ 8 \overline{)488} \\ \underline{48} \\ 8 \\ \underline{8} \\ 0 \end{array} \quad \begin{array}{r} 61 \\ 9 \overline{)549} \\ \underline{54} \\ 9 \\ \underline{9} \\ 0 \end{array}$$

$$\begin{array}{r} 346 \\ \times 2 \\ \hline 692 \end{array} \quad \begin{array}{r} 951 \\ \times 7 \\ \hline 6,657 \end{array} \quad \begin{array}{r} 582 \\ \times 3 \\ \hline 1,746 \end{array}$$

2. Devin made a mistake when completing the division problem below. Can you find his mistake? Once you do, complete the problem correctly.

He forgot to bring down the 8.

$$\begin{array}{r} 14 \\ 6 \overline{)684} \\ \underline{-6} \\ 24 \\ \underline{-24} \\ 0 \end{array} \quad \begin{array}{r} 114 \\ 6 \overline{)684} \\ \underline{-6} \\ 08 \\ \underline{-6} \\ 24 \\ \underline{-24} \\ 0 \end{array}$$

Review

3. Fill in the missing numerators and denominators to make fractions equal to $\frac{1}{2}$.

$$\frac{9}{18} \quad \frac{3}{6} \quad \frac{13}{26} \quad \frac{15}{30} \quad \frac{6}{12} \quad \frac{2}{4} \quad \frac{4}{8} \quad \frac{1}{2} \quad \frac{8}{16} \quad \frac{20}{40} \quad \frac{12}{24}$$

4. Fill in the missing information to make equivalent fractions.

$$\frac{3}{4} = \frac{6}{8} \quad \frac{3}{4} = \frac{12}{16} \quad \frac{3}{4} = \frac{15}{20} \quad \frac{3}{4} = \frac{9}{12}$$

Targeted Multiplication Fact Practice

Practice any problems you missed in your Set D quiz in Lesson 49. Then complete the problems in this section.

12	12	12	12	12	12	12	12	12	12
$\times 3$	$\times 12$	$\times 8$	$\times 5$	$\times 11$	$\times 7$	$\times 4$	$\times 9$	$\times 6$	
36	144	96	60	132	84	48	108	72	
9	3	11	8	5	6	4	7	2	
$\times 12$	$\times 12$	$\times 12$	$\times 12$	$\times 12$	$\times 12$	$\times 12$	$\times 12$	$\times 12$	
108	36	132	96	60	72	48	84	24	

Review

16 oz = 1 lb
2,000 lb = 1 tn
1,000 g = 1 kg

1. Complete each conversion.

8 lb = 128 oz

32 oz = 2 lb

6,000 lb = 3 tn

12 lb = 192 oz

6.35 kg = 6,350 g

4,000 g = 4 kg

2. Simplify each fraction or mixed number, and then write each one as a decimal number.

$\frac{15}{20}$

$\frac{3}{4}$

0.75

$\frac{2}{8}$

$\frac{1}{4}$

0.25

$1\frac{10}{20}$

$1\frac{1}{2}$

1.5

$3\frac{4}{16}$

$3\frac{1}{4}$

3.25

3. Add or subtract the mixed numbers and fraction. Then write the answers in simplest form in the gray boxes.

$5\frac{5}{12} - 1\frac{4}{24} = 4\frac{6}{24}$

$4\frac{1}{4}$

$6\frac{1}{4} + \frac{2}{8} = 6\frac{4}{8}$

$6\frac{1}{2}$

$2\frac{1}{6} + 1\frac{1}{2} = 3\frac{4}{6}$

$3\frac{2}{3}$

4. Complete each problem.

$214 \overline{)6,442}$

$25 \overline{)258}$

$203 \overline{)815}$

$325 \overline{)3,250}$

5. Use the box to divide the number 12 into 3 equal groups. Then answer the question.

What is $\frac{2}{3}$ of 12?

8

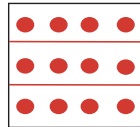

6. Rewrite each problem vertically on scratch paper and complete it.

$195.54 - 84.193 = 111.347$

$0.341 + 730.88 = 731.221$

$8.34 + 274.307 = 282.647$

$8 \overline{)64}$ $5 \overline{)25}$ $4 \overline{)16}$ $5 \overline{)45}$ $4 \overline{)36}$ $3 \overline{)27}$ $5 \overline{)35}$ $6 \overline{)18}$ $6 \overline{)30}$ $8 \overline{)72}$ $12 \overline{)108}$ $12 \overline{)36}$



TREASURE HUNT

Are you ready to go on a treasure hunt? Use the ordered pairs listed to find the path to the treasure chest. As you find each point, write the letter for that ordered pair in the box at the bottom of the next page. Connect the points in order as you travel across the map.



Path to the Treasure

- (5, 1)
- ↓
- (6, 3)
- ↓
- (4, 3)
- ↓
- (3, 4)
- ↓
- (2, 6)
- ↓
- (5, 7)
- ↓
- (7, 7)
- ↓
- (7, 5)
- ↓
- (8, 3)
- ↓
- (9, 2)

REVIEW GAME: UNITS 1 AND 2

- Complete today's Math 4 Mental Math Map Mysteries activity.
- There are no more videos, mini lessons, or practice!

Welcome to Italy! In the next two lessons, we will be taking a trip across the country of Italy, visiting different cities while reviewing some of the most important skills you've learned throughout this course. Follow the itinerary below to move from city to city. Complete each of the problems on the postcard for that city before moving on to the next city.

DAY 1

Your plane lands in Italy at 4:45 PM. The plane ride lasted 2 hours and 20 minutes. At what time did you board the plane?

2:25 PM

Your tour of Italy starts in Bolzano, the capital of the South Tyrol region. This beautiful area offers stunning castles and quaint mountain villages amid endless hills and vineyards.

DAY 2

You hop on a bus for the short trip to the famous city of Venice. The bus leaves at 7:23 AM and arrives at 10:50 AM. How long was the bus ride?

3 hours 27 minutes

The city of Venice stretches across 118 small islands and doesn't have any major roads, just canals! Today, you take a gondola ride through the historic city.



"Buongiorno!" from Bolzano

Write the place value of the underlined digit.

25 <u>1</u> 4	0.2 <u>3</u> 4	7. <u>4</u> 97
<u>hundredths</u>	<u>thousandths</u>	<u>tenths</u>
25 <u>1</u> ,475	7.4 <u>6</u> 5	<u>3</u> ,541,725
<u>thousands</u>	<u>tens</u>	<u>millions</u>

Rewrite each problem vertically on scratch paper and complete it.

115.4 - 84.19 = 31.21

0.385 + 71.25 = 71.635

57.3 - 0.178 = 57.122

347.2 - 6.547 = 340.653

2.7 + 0.69 = 3.39

VACATIONING IN VENICE, ITALY

Round each decimal number to the underlined digit.

<u>6</u> 7.23	1.8 <u>9</u>	39 <u>1</u> .51
<u>67</u>	<u>1.9</u>	<u>392</u>

Round each number to the underlined digit.

<u>2</u> 21,319,022	<u>4</u> 21,815,172	147,784,1 <u>9</u> 2
<u>270,000,000</u>	<u>400,000,000</u>	<u>148,000,000</u>

Arrange these decimal numbers from least to greatest.

32.106	<u>31.026</u>	74.254	<u>74.245</u>
32.160	<u>32.016</u>	74.524	<u>74.254</u>
32.016	<u>32.106</u>	74.245	<u>74.524</u>
31.026	<u>32.160</u>	74.542	<u>74.542</u>
	Greatest		Greatest

COURSE ASSESSMENT

Parent/Teacher

- Read the following information aloud to the child: This assessment is different from the others you have taken in this course. Instead of covering only concepts taught in Unit 4, this assessment covers concepts you have learned throughout the entire course. Problems in this assessment have been carefully designed to assess you on multiple skills at once. For example, a single long division question can cover the long division steps, division with zero in the quotient, dividing by two-digit numbers, and dividing decimals. A question on rounding can assess place value, rounding, and decimal numbers. This assessment does not cover every skill you learned in Math 4. Instead, it focuses on skills you need to know as you start Math 5.
- Here are some tips. First, make sure to read the instructions carefully. Second, do not rush through exercises you think you already know. Third, if you start to get frustrated with one section, try skipping to a different section and then coming back later. The sections do not need to be completed in order.
- For Lesson 119 complete all the exercises with PURPLE headers ONLY. Your parent or teacher will correct the work. If you make one or more mistakes in a section, your parent or teacher will check the orange "Additional Practice" checkbox for that section.
- For Lesson 120 complete all the orange sections that are checked. If you still have trouble with the concept, go back and rewatch the video or reread the mini lesson for that topic.

Student

DECIMAL NUMBERS (LESSONS 76, 87 & 103)

Rewrite each problem vertically and complete it.

$$\begin{array}{r} 241.62 + 92.107 \\ 333.727 \end{array} \qquad \begin{array}{r} 175.845 - 47.5 \\ 128.345 \end{array}$$

Divide or multiply each number by moving the decimal point.

$$\begin{array}{l} 22.47 \div 10 = 2.247 \\ 195.3 \div 100 = 1.953 \\ 12,347 \div 1,000 = 12.347 \end{array} \qquad \begin{array}{l} 4.32 \times 10 = 43.2 \\ 7.489 \times 100 = 748.9 \\ 1.234 \times 1,000 = 1,234 \end{array}$$

In the number below, circle the digit in the thousandths place. Draw a square around the digit in the tenths place. Cross out the digit in the hundredths place.

2,487.9~~8~~0

Additional Practice

Complete each problem.

$$\begin{array}{r} 12.75 \\ + 0.47 \\ \hline 13.22 \end{array} \qquad \begin{array}{r} 157.12 \\ - 41.24 \\ \hline 115.88 \end{array}$$

Divide or multiply each decimal number by moving the decimal point.

$$\begin{array}{l} 21.8 \div 10 = 2.18 \\ 634.2 \div 100 = 6.342 \\ 321.7 \div 1,000 = 0.3217 \end{array}$$

Circle the digit in the hundredths place.

14,517.308

$$\begin{array}{l} 0.78 \times 10 = 7.8 \\ 27.87 \times 100 = 2,787 \\ 2.0478 \times 1,000 = 2,047.8 \end{array}$$

LONG DIVISION

(LESSONS 41, 47, 51, 63, 69, 77, 81, 97, 101, 111 & 113)

Complete each division problem. Remember to write the decimal point in the quotient if necessary.

$$\begin{array}{l} 35.7 \\ 6 \overline{)214.2} \end{array} \qquad \begin{array}{l} 20.4 \\ 18 \overline{)367.2} \end{array} \qquad \begin{array}{l} 684 \text{ R}2 \\ 10 \overline{)6,842} \end{array} \qquad \begin{array}{l} 223 \text{ R}12 \\ 32 \overline{)7,148} \end{array}$$

Additional Practice

Complete each division problem. Remember to write the decimal point in the quotient if necessary.

$$\begin{array}{l} 3.81 \\ 4 \overline{)15.24} \end{array} \qquad \begin{array}{l} 22.48 \\ 21 \overline{)472.08} \end{array} \qquad \begin{array}{l} 361 \text{ R}9 \\ 10 \overline{)3,619} \end{array} \qquad \begin{array}{l} 111 \text{ R}17 \\ 45 \overline{)5,012} \end{array}$$

EXPONENTS & PRIME NUMBERS

(LESSONS 37 & 52)

Convert from factored form to exponent form.

$$\begin{array}{l} 2 \times 2 \times 2 = 2^3 \\ 5 \times 5 \times 5 \times 5 \times 5 = 5^5 \\ 8 \times 8 \times 8 \times 8 \times 8 = 8^6 \\ 3 \times 3 \times 3 \times 3 = 3^4 \end{array}$$

Circle all the prime numbers in the box below.

2 3 4 5 6 7 8 9 10
11 12 13 14 15 16 17 18

Fill in the perfect squares in the chart. The first one has been done.

4 ²	16
8 ²	64
2 ²	4
5 ²	25
3 ²	9
9 ²	81

Additional Practice

Convert from exponent form to factored form.

$$\begin{array}{l} 4^6 = 4 \times 4 \times 4 \times 4 \times 4 \times 4 \\ 7^3 = 7 \times 7 \times 7 \\ 9^5 = 9 \times 9 \times 9 \times 9 \times 9 \\ 6^2 = 6 \times 6 \end{array}$$

Circle all the composite numbers in the box below.

2 3 4 5 6 7 8 9 10
11 12 13 14 15 16 17 18

Fill in the perfect squares in the chart. The first one has been done.

11 ²	121
4 ²	16
10 ²	100
7 ²	49
6 ²	36
12 ²	144



Math 4

MENTAL MATH

Map Mysteries

The Good AND THE Beautiful
CURRICULUM

About This Book

This mental math book correlates with the *Simply Good and Beautiful Math 4 Course Book*, which directs the child to do a lesson box in this mental math book for each lesson (except for lessons that are assessments).

To complete the mental math, the parent or teacher should hold up the book so that the child sees the Questions page and the parent or teacher sees the Answer Key page (or it can be laid flat with the parent or teacher covering the answers with a paper or sticky note). The child should then complete the lesson box number that correlates to his or her lesson in the *Simply Good and Beautiful Math 4 Course Book*, giving the answers aloud. As the child gives the answers, the parent or teacher checks the answers and gives any correction needed. Upon completion of the lesson box, both the parent or teacher and student should place a check mark in the box to mark it as completed.

At the end of each page of four or five lesson boxes, the student is directed to place a sticker from page 71 onto a designated space on the map on page 69. At the end of the course, the student will have a completed picture of the map, and as a reward for completing the course, the child is then able to read the “You-Choose” book included in the course: *Hayden and the Hidden Village*. The map that the child created shows places included in the book.

Students who struggle with a mental math concept should be encouraged to continue through the lesson boxes as several skills will be repeated throughout the book.

Each mental math lesson box is designed to take less than five minutes to complete.

It is most desirable for mental math to be done without the aid of writing anything down. However, if needed, the child may use paper and pencil to help with the problems, with the goal of discontinuing the use of the paper and pencil at some point in the book.

The mental math lesson boxes do not correlate directly with the lessons taught in the *Simply Good and Beautiful Math 4 Course Book*.



LESSON 1

COMPLETE **Add 10 to a Number**

Increase the digit in the tens place by 1. (The tens place is shown in red.)

$23 + 10$ $45 + 10$ $37 + 10$ $82 + 10$

Skip Count

- by 3s from 30 to 60
- by 25s from 400 to 500

LESSON 2

COMPLETE **Add 10 to a Number**

Increase the digit in the tens place by 1. (The tens place is shown in red.)

$220 + 10$ $341 + 10$ $673 + 10$ $384 + 10$

Skip Count

- by 3s from 120 to 150
- backward by 25s from 500 to 400

LESSON 3

COMPLETE **Add 9 to a Number**

Mentally add 10, and then subtract 1 from the sum.

$33 + 9$ $19 + 9$ $35 + 9$ $17 + 9$ $78 + 9$

Calendar

Name the months of the year.

LESSON 4

COMPLETE **Add 10 to a Number**

Increase the digit in the tens place by 1.

$347 + 10$ $222 + 10$ $119 + 10$ $147 + 10$

Skip Count

- by 3s from 210 to 240
- backward by 25s from 625 to 525

LESSON 5

COMPLETE **Subtract 10 from a Number**

Decrease the digit in the tens place by 1.

$24 - 10$ $45 - 10$ $37 - 10$ $16 - 10$

Calendar

There are 12 months in a year. How many months are in 2 years?

Twenty-four months from January is January. What is 25 months from January? What is 14 months from January?



After completing Lesson 5, place this piece onto your map on D-3.

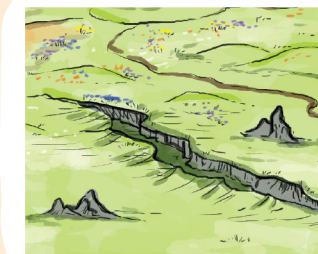

ANSWER KEY

LESSON 1

COMPLETE

Add 10 to a Number

Increase the digit in the tens place by 1. (The tens place is shown in red.)

$23 + 10 = 33$ $45 + 10 = 55$ $37 + 10 = 47$ $82 + 10 = 92$

Skip Count

- by 3s from 30 to 60 30, 33, 36, 39, 42, 45, 48, 51, 54, 57, 60
- by 25s from 400 to 500 400, 425, 450, 475, 500

LESSON 2

COMPLETE

Add 10 to a Number

Increase the digit in the tens place by 1. (The tens place is shown in red.)

$220 + 10 = 230$ $341 + 10 = 351$ $673 + 10 = 683$ $384 + 10 = 394$

Skip Count

- by 3s from 120 to 150 120, 123, 126, 129, 132, 135, 138, 141, 144, 147, 150
- backward by 25s from 500 to 400 500, 475, 450, 425, 400

LESSON 3

COMPLETE

Add 9 to a Number

Mentally add 10, and then subtract 1 from the sum.

$33 + 9 = 42$ $19 + 9 = 28$ $35 + 9 = 44$ $17 + 9 = 26$ $78 + 9 = 87$

Calendar

Name the months of the year. January, February, March, April, May, June, July, August, September, October, November, December

LESSON 4

COMPLETE

Add 10 to a Number

Increase the digit in the tens place by 1.

$347 + 10 = 357$ $222 + 10 = 232$ $119 + 10 = 129$ $147 + 10 = 157$

Skip Count

- by 3s from 210 to 240 210, 213, 216, 219, 222, 225, 228, 231, 234, 237, 240
- backward by 25s from 625 to 525 625, 600, 575, 550, 525

LESSON 5

COMPLETE

Subtract 10 from a Number

Decrease the digit in the tens place by 1.

$24 - 10 = 14$ $45 - 10 = 35$ $37 - 10 = 27$ $16 - 10 = 6$

Calendar

There are 12 months in a year. How many months are in 2 years? 24
 Twenty-four months from January is January. What is 25 months from January? February
 What is 14 months from January? March

NOTES

~~~~~

~~~~~

~~~~~

~~~~~

~~~~~

LESSON 115

COMPLETE

Change from a Dollar

Determine the change from a dollar for each amount. Count up to the next ten, and then count by tens to 100.

12¢      47¢      39¢      24¢      61¢      81¢

Add Money Amounts

Add \$2.00, and then subtract 2 cents from the sum.

\$4.15 + \$1.98    \$6.37 + \$1.98    \$9.29 + \$1.98    \$1.98 + \$2.75

Skip Count

- by 25s from 500 to 700
- backward by 25s from 700 to 500

LESSON 116

COMPLETE

Roman Numerals

State the number for each Roman numeral.

XXXII      XLIV      LXVII      XLII      XCVI      XCIV

Add 29 to a Number

Mentally add 30, and then subtract 1 from the sum.

13 + 29      78 + 29      29 + 175      29 + 90

Factor and Product

Point to each number and state whether it is a factor or product:  $\frac{4}{3} \times 12$

Add 4 Numbers

25 + 25 + 15 + 15      25 + 150 + 75 + 15      30 + 40 + 20 + 16

LESSON 117

COMPLETE

Roman Numerals

State the number for each Roman numeral.

LVII      LXXII      LIII      XXXV      LXVI      XXXI

Add 4 Numbers

25 + 25 + 15 + 50      25 + 125 + 75 + 15      25 + 75 + 15 + 50

LESSON 118

COMPLETE

Skip Count

- backward by 3s from 105 to 90
- by 20s from 20 to 200

Story Problems

- Each pair of students needs a jump rope. There are 36 students. How many jump ropes are needed?
- How many inches are in 4 feet 2 inches?

There are no mental math lesson boxes for Lessons 119 and 120 as they are assessments.



After completing Lesson 118, place the pieces below onto your map where indicated.



B-2

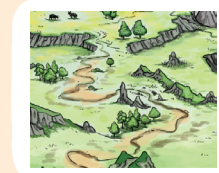

B-1



## LESSON 115

COMPLETE

**Change from a Dollar**

Determine the change from a dollar for each amount. Count up to the next ten, and then count by tens to 100.

$12¢$   $88¢$   $47¢$   $53¢$   $39¢$   $61¢$   $24¢$   $76¢$   $61¢$   $39¢$   $81¢$   $19¢$

**Add Money Amounts**

Add \$2.00, and then subtract 2 cents from the sum.

$$\begin{array}{r} \$4.15 + \$1.98 \\ \hline \$6.13 \end{array}$$

$$\begin{array}{r} \$6.37 + \$1.98 \\ \hline \$8.35 \end{array}$$

$$\begin{array}{r} \$9.29 + \$1.98 \\ \hline \$11.27 \end{array}$$

$$\begin{array}{r} \$1.98 + \$2.75 \\ \hline \$4.73 \end{array}$$

**Skip Count**

- by 25s from 500 to 700 500, 525, 550, 575, 600, 625, 650, 675, 700
- backward by 25s from 700 to 500 700, 675, 650, 625, 600, 575, 550, 525, 500

## LESSON 116

COMPLETE

**Roman Numerals**

State the number for each Roman numeral.

$XXXII$  32  $XLIV$  44  $LXVII$  67  $XLII$  42  $XCVI$  96  $XCIV$  94

**Add 29 to a Number**

Mentally add 30, and then subtract 1 from the sum.

$$\begin{array}{r} 13 + 29 \\ \hline 42 \end{array}$$

$$\begin{array}{r} 78 + 29 \\ \hline 107 \end{array}$$

$$\begin{array}{r} 29 + 175 \\ \hline 204 \end{array}$$

$$\begin{array}{r} 29 + 90 \\ \hline 119 \end{array}$$

**Factor and Product**

Point to each number and state whether it is a factor or product:

$$\begin{array}{r} 4 \text{ factor} \\ \times 3 \text{ factor} \\ \hline 12 \text{ product} \end{array}$$

**Add 4 Numbers**

$$\begin{array}{r} 25 + 25 + 15 + 15 \\ \hline 80 \end{array}$$

$$\begin{array}{r} 25 + 150 + 75 + 15 \\ \hline 265 \end{array}$$

$$\begin{array}{r} 30 + 40 + 20 + 16 \\ \hline 106 \end{array}$$

## LESSON 117

COMPLETE

**Roman Numerals**

State the number for each Roman numeral.

$LVII$  57  $LXXII$  72  $LIII$  53  $XXXV$  35  $LXVI$  66  $XXXI$  31

**Add 4 Numbers**

$$\begin{array}{r} 25 + 25 + 15 + 50 \\ \hline 115 \end{array}$$

$$\begin{array}{r} 25 + 125 + 75 + 15 \\ \hline 240 \end{array}$$

$$\begin{array}{r} 25 + 75 + 15 + 50 \\ \hline 165 \end{array}$$

## LESSON 118

COMPLETE

**Skip Count**

- backward by 3s from 105 to 90 105, 102, 99, 96, 93, 90
- by 20s from 20 to 200 20, 40, 60, 80, 100, 120, 140, 160, 180, 200

**Story Problems**

- Each pair of students needs a jump rope. There are 36 students. How many jump ropes are needed? 18 jump ropes
- How many inches are in 4 feet 2 inches? 50 inches

There are no mental math lesson boxes for Lessons 119 and 120 as they are assessments.

NOTES

Wait to read  
this book until  
after you have  
completed the  
course book!

## The Adventure Begins

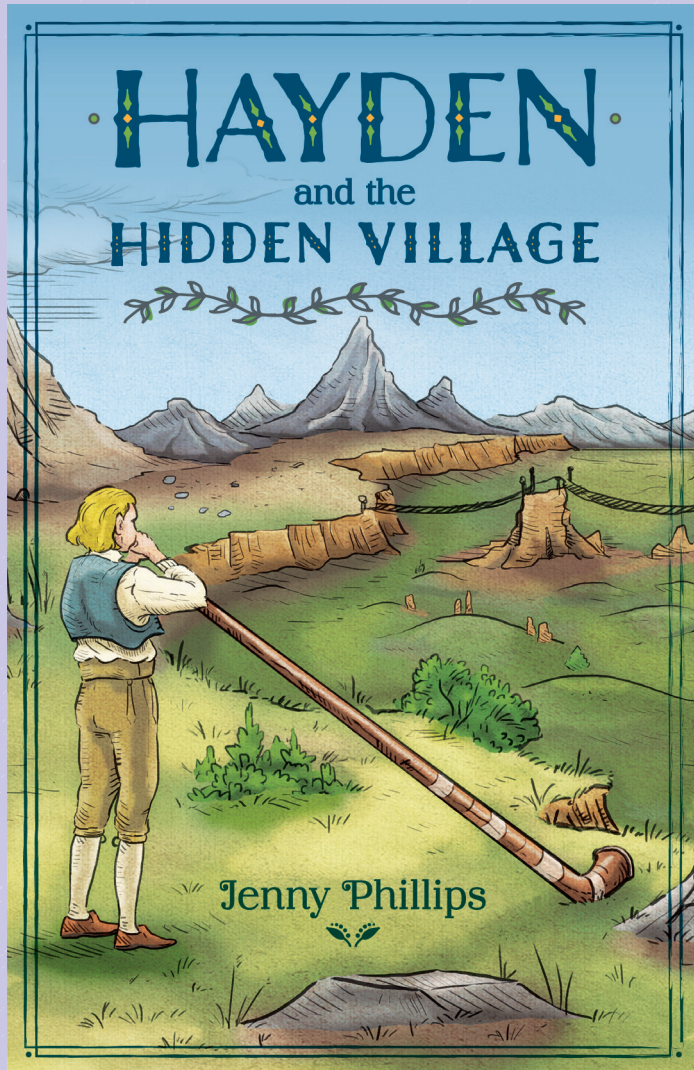

**L**ONG AGO, A BOY NAMED HAYDEN WAS about to have an adventure. He had no idea, however, because this summer day started out calmly. The sweet melody of cowbells and the whispering wind gave no hint of anything unique or unusual about this day. Hayden lay back on the mountain grass and folded his hands across his stomach, using his rolled-up sweater as a pillow. As he stared up at the clouds collecting into big puffs, he began to sing the song he had been making up in his mind about homophones. For, you see, he did most of his schoolwork each day up in the high pasture as he tended the cows and made sure they did not get close to the cliffs.

*“H - a - i - r” is how I say*

*Something that I brush each day.*

*“H - a - r - e” is a mammal that I love to see.*

*“B - r - a - k - e” makes the wagon stop for me.*

*“B - r - e - a - k” is not good for my knee.*



Hayden repeated the song again and then smiled proudly. His mother, who had passed away a couple of years ago, had loved learning. She had collected as many books as she could for their small home library. The family had tried to follow her love of learning after she was gone, and Father took up the role of teacher.

One of the cows had come near Hayden, and he spoke to her, as he often spoke to his cows. “It might be lonely up here in the high pasture,” he said to the dark tan cow named Buttercup, “but it sure is beautiful.”

Buttercup didn’t even look up as she feasted on mouthfuls of green, dew-covered grass.



“Hey! ‘Beautiful’ is one of my spelling words,” said Hayden, still talking to the cow. “Father said to practice my spelling words three times today. Tell me, Buttercup, if I get it right: b - e - a - u - t - i - f - u - l. And here it is in syllables: beau - ti - ful. Are you impressed?”

The cow looked up and let out a short moo, looking as if she were not impressed.

“OK, if you think it is easy, you try to spell ‘beautiful,’ Buttercup. Try breaking it into syllables: beau - ti - ful.”

The cow turned, flipped its tail at an annoying fly, and ambled away.

Hayden laughed and rolled onto his stomach. Resting his chin on his hands, he gazed out across the familiar but stunning landscape. His soul soaked in all the wonders around him—a little piece of heaven. He followed the outlines of the jagged mountain peaks, and he viewed the rolling hills carpeted in softly blowing grass and the sweeping fields of pretty yellow and white wildflowers in the valley. He spotted a group of deer by the church in the valley. Hayden had grown so fond of this area since his family had moved here four years ago. Slowly, Hayden turned his gaze far into the distance to admire the pretty Silver Falls cascading majestically off a cliff into Emerald Lake. Today, he also dared to study the thick pine forest in the valley past the waterfall, a sight he usually avoided because it made him so nervous.

“The Forest of Fog,” Hayden said aloud. He pondered what he had heard about the forest. No one he knew had ever gone into that forest. Supposedly, there was a fog in the

Hayden brought the cows home just before lunch. He didn't like leaving Chloe home all day since Father was gone. He planned on eating lunch with Chloe and Thomas and then taking Chloe with him back up to the high pasture for the rest of the day.

As he neared the house, Hayden was surprised that Chloe didn't run out to meet him as she normally did when she heard the cowbells tinkling down the little road. After taking care of the cows in a hurry, he burst into the house.

"Chloe!" his voice echoed in the little home. No one was there, but there was a note on the table. It was in Chloe's handwriting:

*Thomas ran away. I'm going to follow him.*

*I'll be OK. Don't worry.*

*Follow him!* thought Hayden. *That was a terrible idea!* Hayden was not annoyed with Chloe; he was frightened for her! *An eight-year-old girl should not be out alone. There were snakes and cliffs and—* Hayden's imagination went wild. He ran to the stable and found only the brown horse; the white horse was missing. "Oh no!" he cried as he ran a hand through his hair. "What should I do?"



## You Choose



If Hayden overcomes his fear of horses and rides to Mr. Bilxby's farm for help, go to **Part A** on page 56.

OR



If Hayden runs to the high pasture where he can see the whole valley and maybe spot Thomas or Chloe, skip to **Part B** on page 57.







Hayden had not ridden a horse since he had fallen off one last year. He was scared. However, little Chloe's happy face appeared in his mind. What a dear girl with her swinging braids and her rosy cheeks. The siblings had grown so close after their mother's death. Chloe was in danger. "I don't care if I break a bone; I'm going to ride to Farmer Bilxby's. Maybe he can help me. He has helped our family with past emergencies." He quickly collected a loaf of bread, a rope, a pocketknife, and a jug of water. He wrapped the items in a blanket and threw them in a basket on the horse's side. Then he rode off, following the narrow road to Mr. Bilxby's farm with his hair flying in the wind.

Farmer Bilxby was not home, and Hayden saw no sign of Chloe or Thomas. Once again, he found himself not knowing what to do as he tried to collect his thoughts.



## You Choose



If Hayden rides his horse to Abe's home to find help, skip to **Part C** on page 58.

OR



If Hayden goes to the church and climbs the bell tower to see if he can see Chloe or Thomas somewhere in the valley, skip to **Part E** on page 64.



# Map



|   | 1 | 2 | 3 | 4 | 5 |
|---|---|---|---|---|---|
| A |   |   |   |   |   |
| B |   |   |   |   |   |
| C |   |   |   |   |   |
| D |   |   |   |   |   |
| E |   |   |   |   |   |



# Stickers

